

AVH·AVS·NAVR series

Corrosion-resistant Solenoid Valves

www.advance-e.jp

INDEX



AVH·AVS·NAVR series

Corrosion-resistant Solenoid Valves

AVH-1*1*	02·03	NAVR-0*0*	18·19
AVH-2*1*	04·05	NAVR-1*1*	20·21
AVH-3*3*	06·07	NAVR-2*1*	22·23
AVH-4*4*	08·09	NAVR-3*3*	24·25
AVS-1*1*	10·11	NAVR-4*4*	26·27
AVS-2*1*	12·13		
AVS-3*3*	14·15		
AVS-4*4*	16·17		

Export Control

●Export control is aimed at preventing the proliferation of weapons of mass destruction and other sensitive items to countries and regions of security concern or terrorist organizations. Export transactions of goods and technology that have potential weapons of mass destruction (WMD)/ conventional weapons applications are regulated under laws and regulations.

●To ensure safety by maintaining international peace and security, a license may be required from governmental authorities in order to export or provide products or technologies within this catalog. The regulation for export of cargos and technologies is defined by the following four regimes as well as governmental authorities of each country.

Nuclear Suppliers Group (NSG)
Australia Group (AG)

Missile Technology Control Regime (MTCR)
Wassenaar Arrangement (WA)

●Be sure to comply with each country's export control laws and regulations when exporting or providing products or technologies within this catalog.

※Please contact us if you have any questions.

AVH·AVS·NAVR series

Corrosion-resistant Solenoid Valve

An electrically operated valve. Very compact. Wetted material is fluoropolymer which is highly resistant to chemical.



Corrosion-resistant Solenoid Valve

AVH-1*1*



Specifications

Model Code	AVH-121*	AVH-161*	AVH-131*
Structure	2-way(Normally Closed)	2-way(Normally Open)	3-way
Orifice Size	φ1.2 Equivalency [mm]		
Connection Size	M6 P=1.0		
Cv	0.04		
Applicable Media	DI Water, Corrosive Fluid		
Media Pressure	IN: -50~200kPa OUT: 0~50kPa	IN: 0~200kPa OUT: 0~50kPa	COM: -50~100kPa NO,NC: 0~50kPa
Media Temperature	10~50°C		
Ambient Temperature	10~50°C		
Power Consumption	2.4W		
Coil Temperature Rise	60°C [degrees C (or less)]		
Insulation Class	Class B (JIS C 4003)		
Wetted Material	Valve Body: PTFE Diaphragm: PTFE	Valve Body: PTFE Diaphragm: PTFE	Valve Body: PTFE Diaphragm: PTFE Stem: Sapphire

*Specifications are subject to change without notice.

Model Selection Table

AVH-1*1*

Voltage
1: DC 12V
2: DC 24V

Structure
2: 2-way (Normally Closed)
3: 3-way
6: 2-way (Normally Open)

Dimensional Drawing

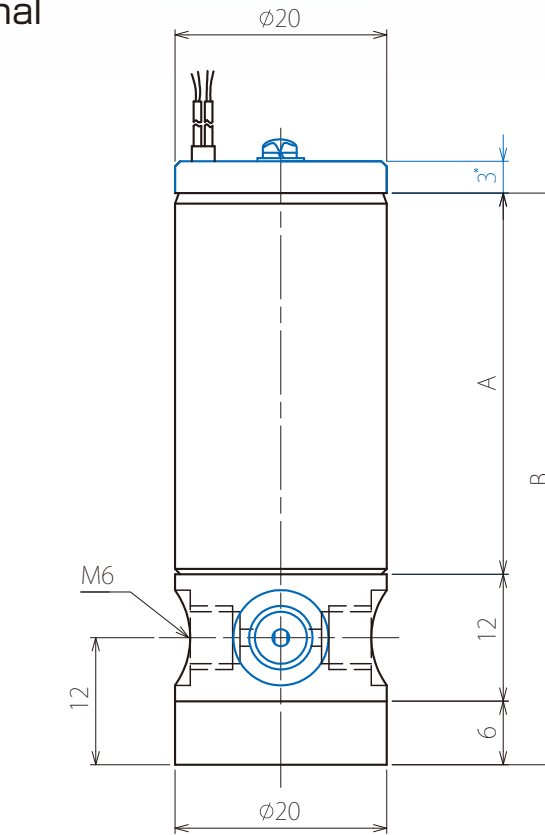

	A	B
AVH-121*	35	53
AVH-161*	36	54
AVH-131*		

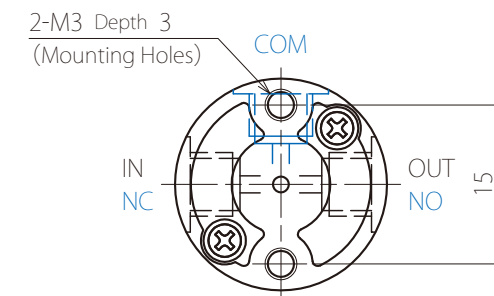

Blue outlines represent 3-way valve and top portion () of normally open 2-way valve.

(unit : mm)

Flow Rate Cv:0.04

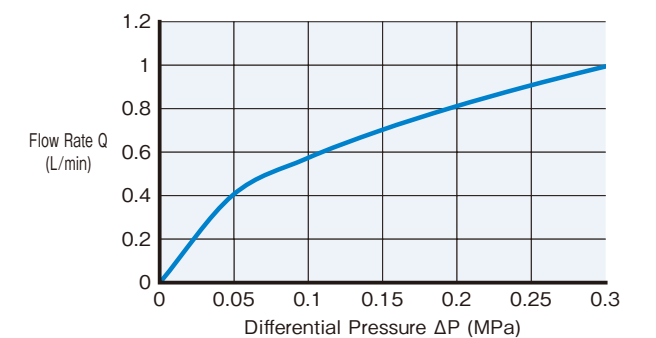

Corrosion-resistant Solenoid Valve

AVH-2*1*



Specifications

Model Code	AVH-221*	AVH-261*	AVH-231*
Structure	2-way(Normally Closed)	2-way(Normally Open)	3-way
Orifice Size	φ1.6 Equivalency [mm]		
Connection Size	M6 P=1.0		
Cv	0.05		
Applicable Media	DI Water, Corrosive Fluid		
Media Pressure	IN: -90~300kPa OUT: 0~100kPa	IN: -50~200kPa OUT: 0~50kPa	COM: -90~100kPa NO,NC: 0~100kPa
Media Temperature	10~50°C		
Ambient Temperature	10~50°C		
Power Consumption	3.0W		
Coil Temperature Rise	60°C [degrees C (or less)]		
Insulation Class	Class B (JIS C 4003)		
Wetted Material	Valve Body: PFA	Valve Body: PFA	Valve Body: PFA
	Diaphragm: PTFE	Diaphragm: PTFE	Diaphragm: PTFE
			Stem: Sapphire

*Specifications are subject to change without notice.

Model Selection Table

AVH-2*1*

Voltage
1: DC 12V
2: DC 24V

Structure
2: 2-way (Normally Closed)
3: 3-way
6: 2-way (Normally Open)

Dimensional Drawing

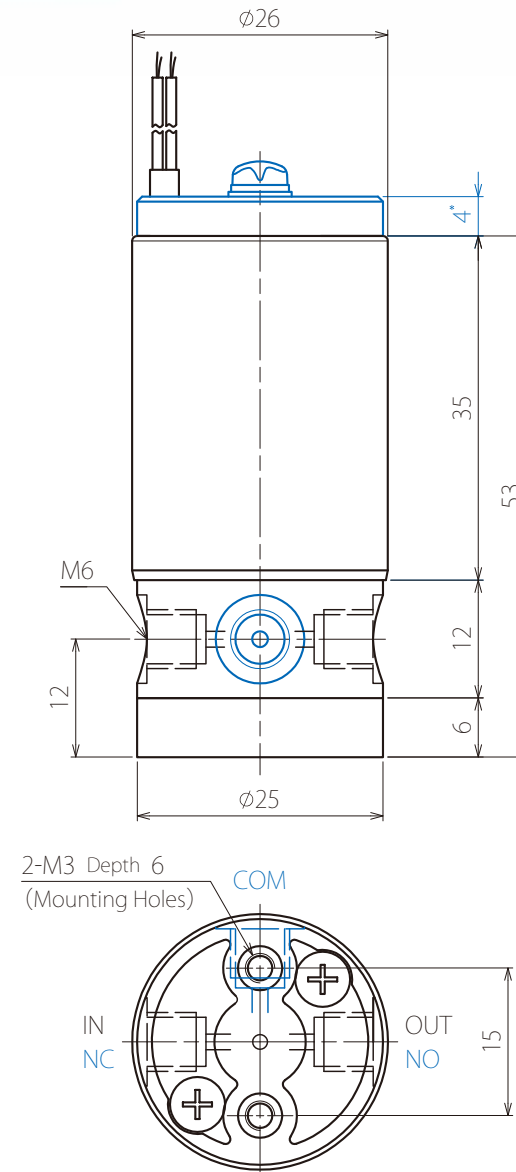

Blue outlines represent 3-way valve and top portion () of normally open 2-way valve.

(unit : mm)

Flow Rate Cv:0.05

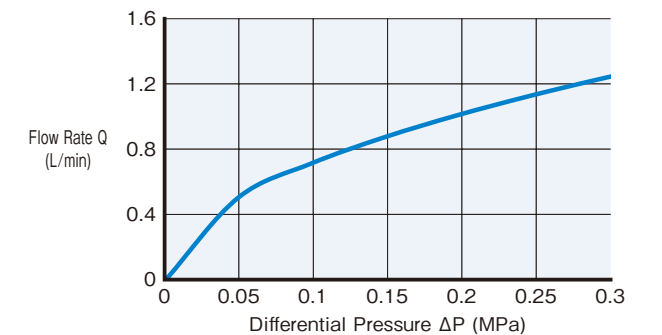

Corrosion-resistant Solenoid Valve

AVH-3*3*



Specifications

Model Code	AVH-323*	AVH-363*	AVH-333*
Structure	2-way(Normally Closed)	2-way(Normally Open)	3-way
Orifice Size	φ3.0 Equivalency [mm]		
Connection Size	Rc1/8		
Cv	0.13		0.1
Applicable Media	DI Water, Corrosive Fluid		
Media Pressure	IN: -90~300kPa OUT: 0~100kPa	IN: -90~300kPa OUT: 0~100kPa	COM: -90~200kPa NO,NC: 0~100kPa
Media Temperature	10~50°C		
Ambient Temperature	10~50°C		
Power Consumption	5.0W		
Coil Temperature Rise	60°C [degrees C (or less)]		
Insulation Class	Class B (JIS C 4003)		
Wetted Material	Valve Body: PTFE	Valve Body: PTFE	Valve Body: PTFE
	Diaphragm: PTFE	Diaphragm: PTFE	Diaphragm: PTFE
			Stem: Sapphire

*Specifications are subject to change without notice.

Model Selection Table

AVH-3*3*

Voltage
1: DC 12V
2: DC 24V
5: AC 100V

Structure
2: 2-way (Normally Closed)
3: 3-way
6: 2-way (Normally Open)

Dimensional Drawing

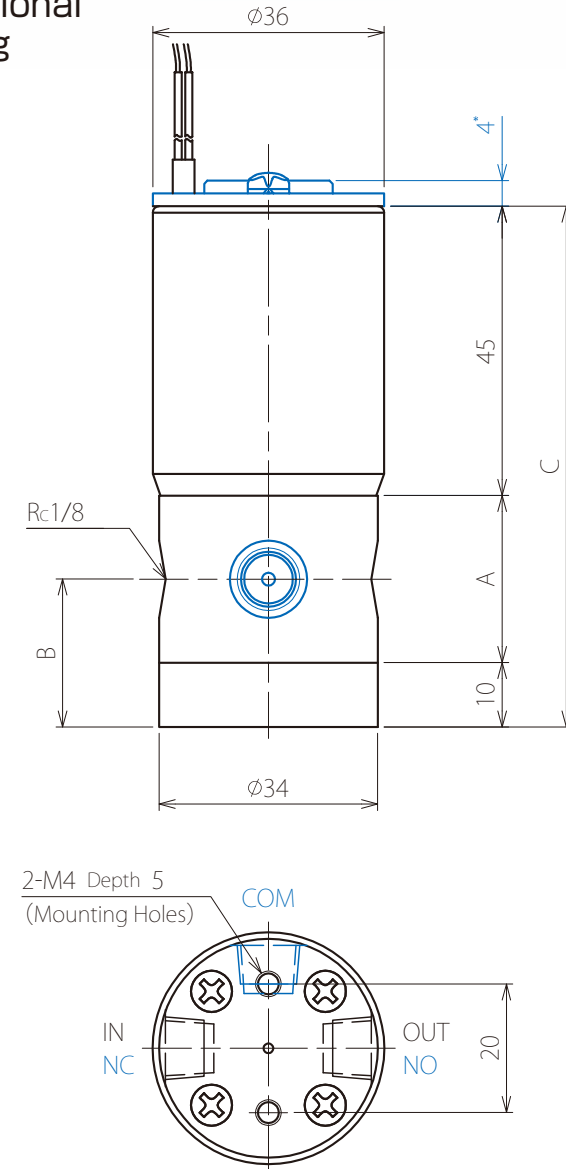

	A	B	C
AVH-323*	24	20	79
AVH-363*			
AVH-333*	26	23	81

Blue outlines represent 3-way valve and top portion () of normally open 2-way valve.

(unit : mm)

Flow Rate Cv:0.13

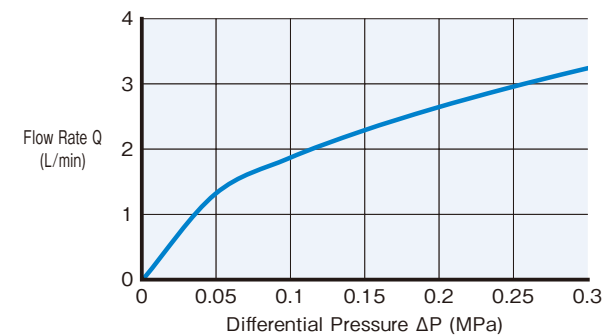

Flow Rate Cv:0.1

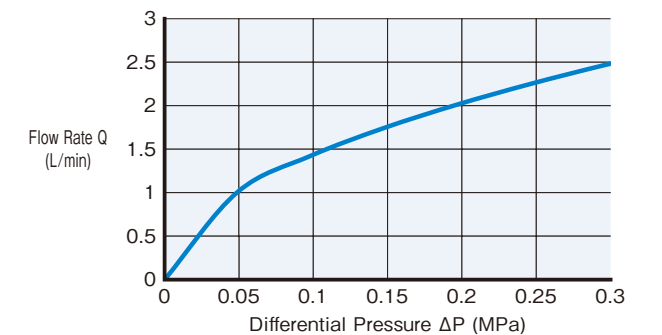

Corrosion-resistant Solenoid Valve

AVH-4*4*



Specifications

Model Code	AVH-424*	AVH-464*	AVH-434*
Structure	2-way(Normally Closed)	2-way(Normally Open)	3-way
Orifice Size	φ5.0 Equivalency [mm]		
Connection Size	Rc1/4		
Cv	0.3		
Applicable Media	DI Water, Corrosive Fluid		
Media Pressure	IN: -90~300kPa OUT: 0~100kPa	IN: -90~300kPa OUT: 0~100kPa	COM: -90~200kPa NO,NC: 0~50kPa
Media Temperature	10~50°C		
Ambient Temperature	10~50°C		
Power Consumption	10W		
Coil Temperature Rise	70°C [degrees C (or less)]		
Insulation Class	Class B (JIS C 4003)		
Wetted Material	Valve Body: PTFE	Valve Body: PTFE	Valve Body: PTFE
	Diaphragm: PTFE	Diaphragm: PTFE	Diaphragm: PTFE
			Stem: PCTFE

*Specifications are subject to change without notice.

Model Selection Table

AVH-4*4*

Voltage
1: DC 12V
2: DC 24V
5: AC 100V

Structure
2: 2-way (Normally Closed)
3: 3-way
6: 2-way (Normally Open)

Dimensional Drawing

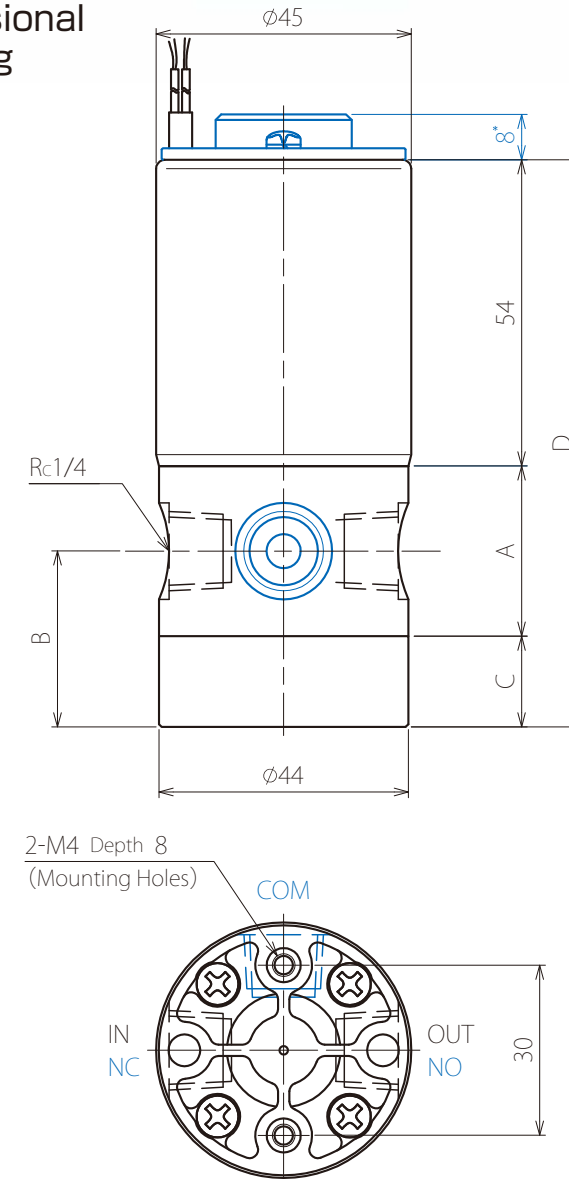

	A	B	C	D
AVH-424*	31	24	12	97
AVH-464*	30	31	16	100

Blue outlines represent 3-way valve and top portion () of normally open 2-way valve.

(unit : mm)

Flow Rate Cv:0.3

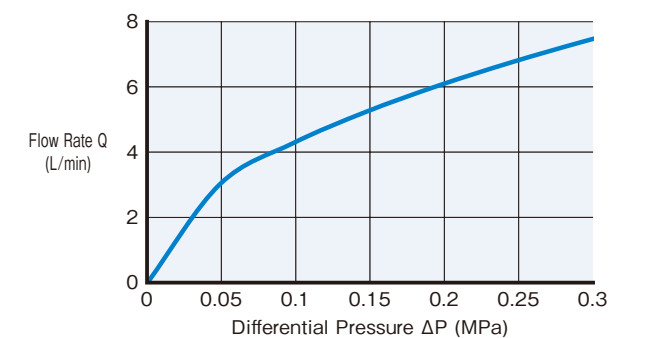

Corrosion-resistant Solenoid Valve

AVS-1*1*



Specifications

Model Code	AVS-121*	AVS-161*	AVH-131*
Structure	2-way(Normally Closed)	2-way(Normally Open)	3-way
Orifice Size	φ1.2 Equivalency [mm]		
Connection Size	M6 P=1.0		
Cv	0.04		
Applicable Media	DI Water, Corrosive Fluid		
Media Pressure	IN: -50~200kPa OUT: 0~50kPa	IN: 0~200kPa OUT: 0~50kPa	COM: -50~100kPa NO,NC: 0~50kPa
Media Temperature	10~50°C		
Ambient Temperature	10~50°C		
Power Consumption	2.4W		
Coil Temperature Rise	60°C [degrees C (or less)]		
Insulation Class	Class B (JIS C 4003)		
Wetted Material	Valve Body: PTFE	Valve Body: PTFE	Valve Body: PTFE
	Diaphragm: FKM	Diaphragm: FKM	Diaphragm: FKM
			Stem: PTFE

*Specifications are subject to change without notice.

Model Selection Table

AVS-1*1*

Voltage
1: DC 12V
2: DC 24V

Structure
2: 2-way (Normally Closed)
3: 3-way
6: 2-way (Normally Open)

Dimensional Drawing

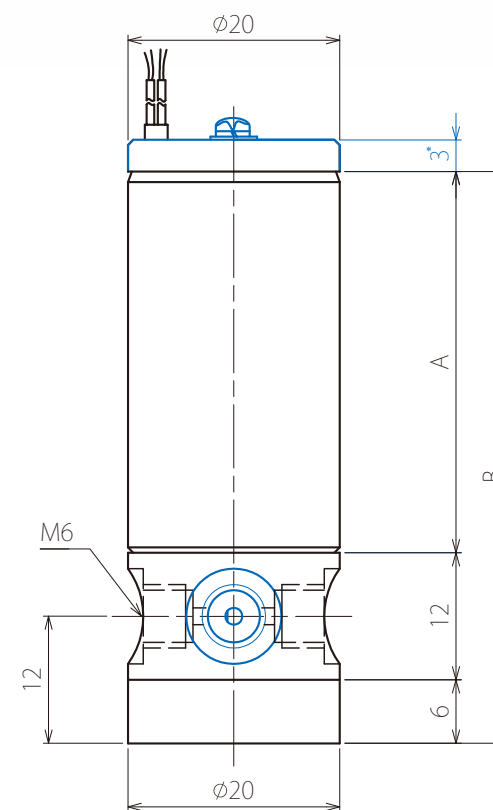

	A	B
AVH-121*	35	53
AVH-161*	36	54
AVH-131*		

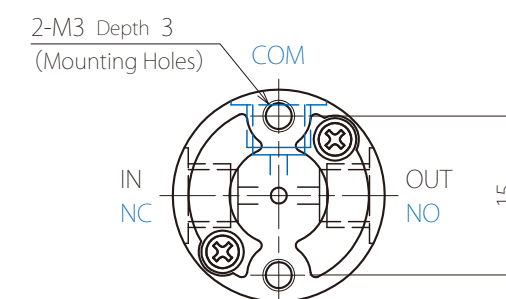

Blue outlines represent 3-way valve and top portion () of normally open 2-way valve.

(unit : mm)

Flow Rate Cv:0.04

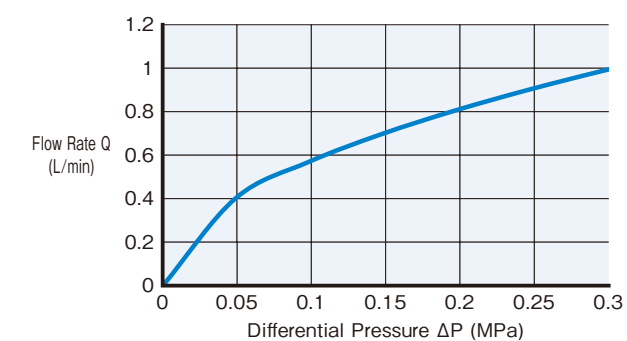

Corrosion-resistant Solenoid Valve

AVS-2*1*



Specifications

Model Code	AVS-221*	AVS-261*	AVS-231*
Structure	2-way(Normally Closed)	2-way(Normally Open)	3-way
Orifice Size	φ1.6 Equivalency [mm]		
Connection Size	M6 P=1.0		
Cv	0.05		
Applicable Media	DI Water, Corrosive Fluid		
Media Pressure	IN: -50~200kPa OUT: 0~50kPa	IN: 0~200kPa OUT: 0~50kPa	COM: 0~100kPa NO,NC: 0~50kPa
Media Temperature	10~50°C		
Ambient Temperature	10~50°C		
Power Consumption	3.0W		
Coil Temperature Rise	60°C [degrees C (or less)]		
Insulation Class	Class B (JIS C 4003)		
Wetted Material	Valve Body: PFA	Valve Body: PFA	Valve Body: PFA
	Diaphragm: FKM	Diaphragm: FKM	Diaphragm: FKM
			Stem: PTFE

*Specifications are subject to change without notice.

Model Selection Table

AVS-2*1*

Voltage
1: DC 12V
2: DC 24V

Structure
2: 2-way (Normally Closed)
3: 3-way
6: 2-way (Normally Open)

Dimensional Drawing

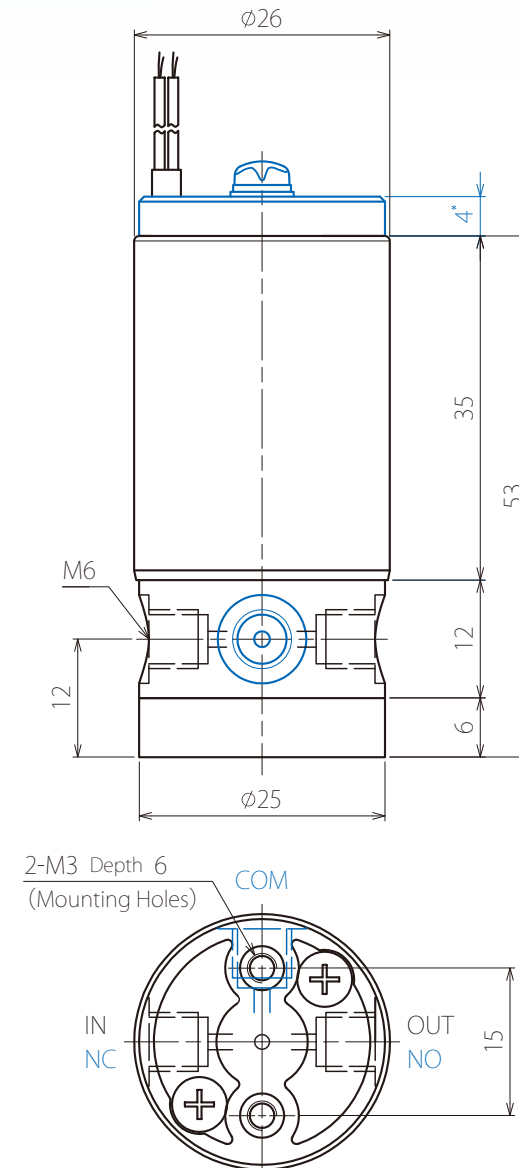

Blue outlines represent 3-way valve and top portion () of normally open 2-way valve.

(unit : mm)

Flow Rate Cv:0.05

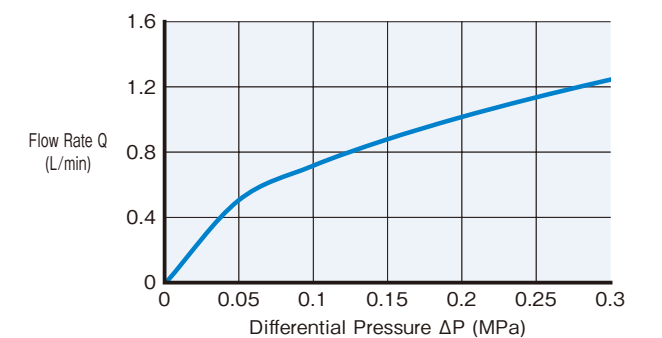

Corrosion-resistant Solenoid Valve

AVS-3*3*



Specifications

Model Code	AVS-323*	AVS-363*	AVS-333*
Structure	2-way(Normally Closed)	2-way(Normally Open)	3-way
Orifice Size	φ3.0 Equivalency [mm]		
Connection Size	Rc1/8		
Cv	0.13		
Applicable Media	DI Water, Corrosive Fluid		
Media Pressure	IN: 0~200kPa OUT: 0~50kPa	IN: 0~200kPa OUT: 0~50kPa	COM: 0~200kPa NO,NC: 0~50kPa
Media Temperature	10~50°C		
Ambient Temperature	10~50°C		
Power Consumption	5.0W		
Coil Temperature Rise	60°C [degrees C (or less)]		
Insulation Class	Class B (JIS C 4003)		
Wetted Material	Valve Body: PTFE Diaphragm: FKM	Valve Body: PTFE Diaphragm: FKM	Valve Body: PTFE Diaphragm: FKM Stem: PTFE

*Specifications are subject to change without notice.

Model Selection Table

AVS-3*3*

Voltage
1: DC 12V
2: DC 24V
5: AC 100V

Structure
2: 2-way (Normally Closed)
3: 3-way
6: 2-way (Normally Open)

Dimensional Drawing

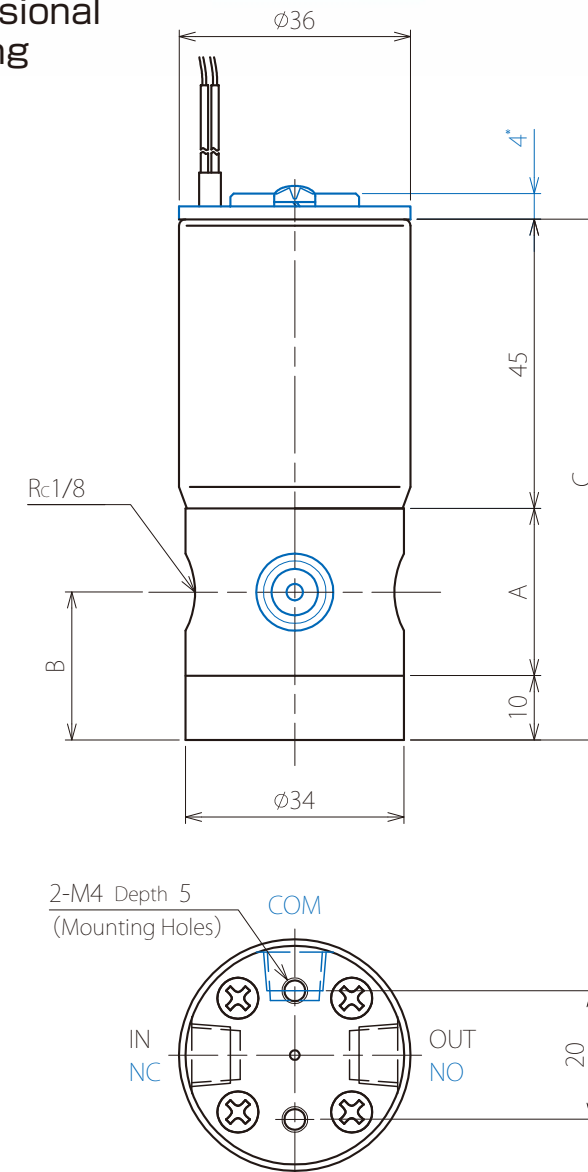

	A	B	C
AVS-323*	24	20	79
AVS-363*	24	20	79
AVS-333*	26	23	81

*Blue outlines represent 3-way valve and top portion (※) of normally open 2-way valve.

(unit : mm)

Flow Rate Cv:0.13

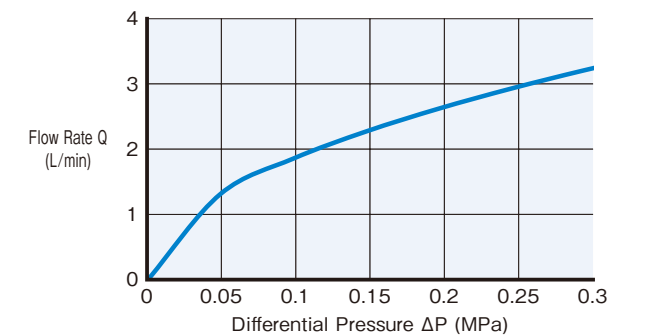

Corrosion-resistant Solenoid Valve

AVS-4*4*



Specifications

Model Code	AVS-424*	AVS-464*	AVS-434*
Structure	2-way(Normally Closed)	2-way(Normally Open)	3-way
Orifice Size	φ5.0 Equivalency [mm]		
Connection Size	Rc1/4		
Cv	0.3		
Applicable Media	DI Water, Corrosive Fluid		
Media Pressure	IN: 0~200kPa OUT: 0~50kPa	IN: 0~200kPa OUT: 0~50kPa	COM: 0~100kPa NO,NC: 0~50kPa
Media Temperature	10~50°C		
Ambient Temperature	10~50°C		
Power Consumption	10W		
Coil Temperature Rise	70°C [degrees C (or less)]		
Insulation Class	Class B (JIS C 4003)		
Wetted Material	Valve Body: PTFE Diaphragm: FKM	Valve Body: PTFE Diaphragm: FKM	Valve Body: PTFE Diaphragm: FKM Stem: PTFE

*Specifications are subject to change without notice.

Model Selection Table

AVS-4*4*

Voltage
1: DC 12V
2: DC 24V
5: AC 100V

Structure
2: 2-way (Normally Closed)
3: 3-way
6: 2-way (Normally Open)

Dimensional Drawing

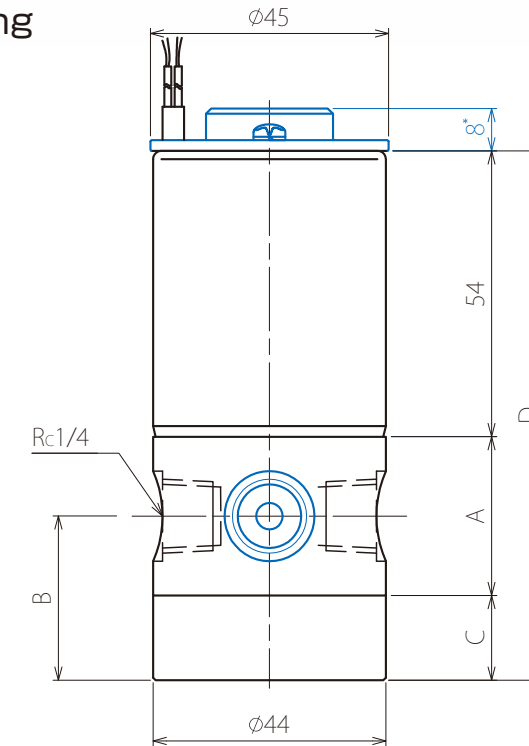

	A	B	C	D
AVS-424*	31	24	12	97
AVS-464*	30	31	16	100

2-M4 Depth 8
(Mounting Holes)

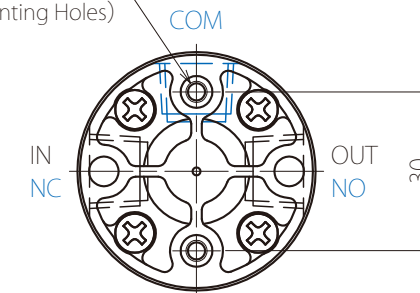

*Blue outlines represent 3-way valve and top portion (※) of normally open 2-way valve.

(unit : mm)

Flow Rate Cv:0.3

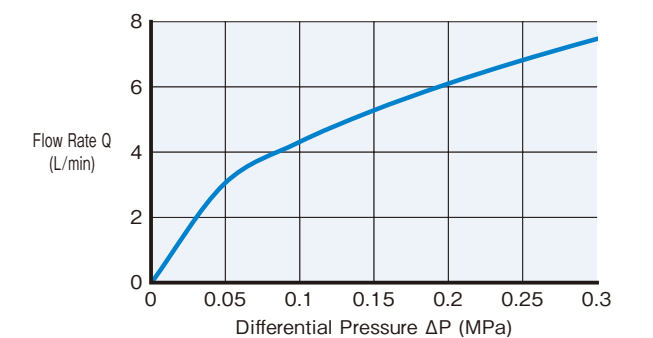

Corrosion-resistant Solenoid Valve

NAVR-0*0*



Specifications

Model Code	NAVR-020*	NAVR-030*
Structure	2-way (Normally Closed)	3-way
Orifice Size	φ1.0 Equivalency [mm]	
Connection Size	M5 P=0.8	
Cv	0.02	0.014
Applicable Media	DI Water, Corrosive Fluid	
Media Pressure	IN: -40~200kPa OUT: 0~50kPa	COM: -40~100kPa NO,NC: 0~50kPa
Media Temperature	10~50°C	
Ambient Temperature	10~50°C	
Power Consumption	2.0W	
Coil Temperature Rise	50°C [degrees C (or less)]	
Insulation Class	Class B (JIS C 4003)	
Wetted Material	Valve Body: PTFE	Valve Body: PTFE
	Diaphragm: PTFE+FFKM	Diaphragm: PTFE+FFKM
	Plug: Zirconia	Stem: Alumina
		Plug: Zirconia Base: PTFE
Accessory	Fixing fitting	

*Specifications are subject to change without notice.

Model Selection Table

NAVR-0*0*

Voltage
1: DC 12V
2: DC 24V

Structure
2: 2-way (Normally Closed)
3: 3-way

Dimensional Drawing

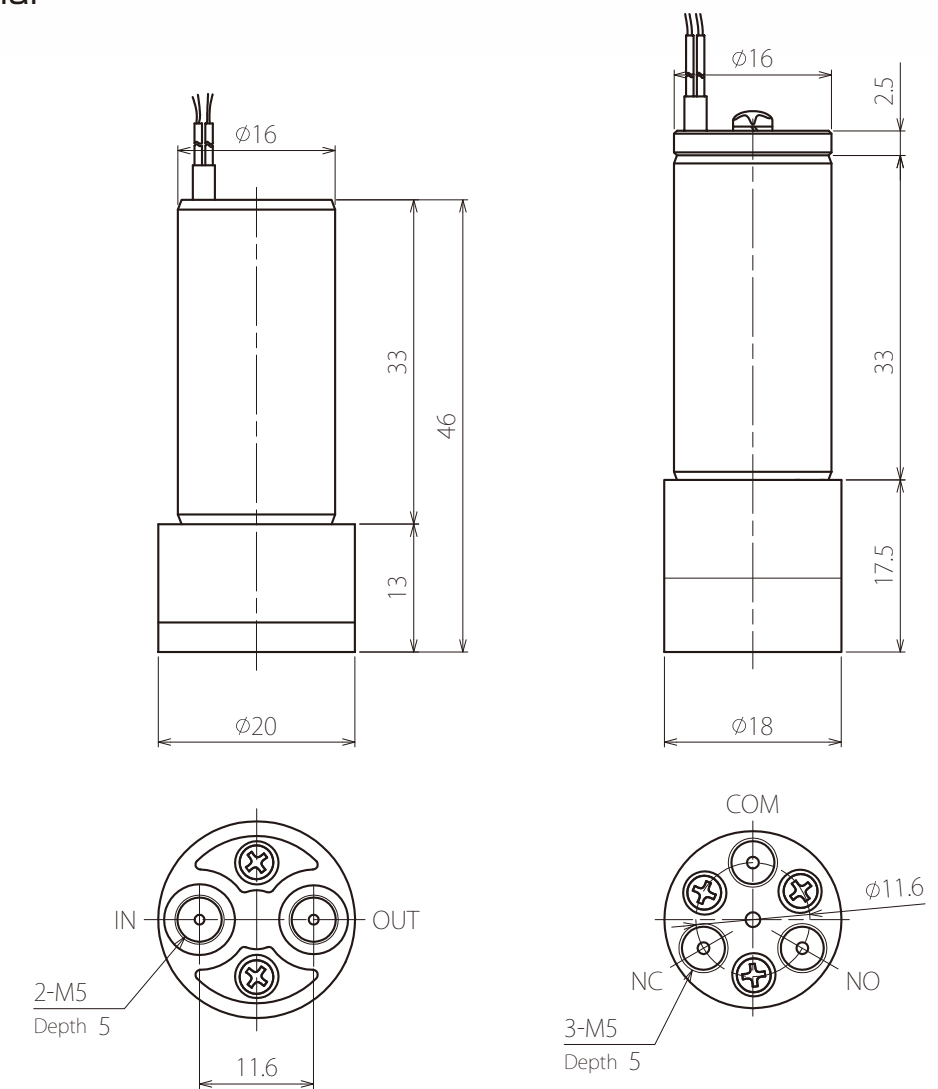

NAVR-020*

NAVR-030*

(unit : mm)

Flow Rate Cv:0.02

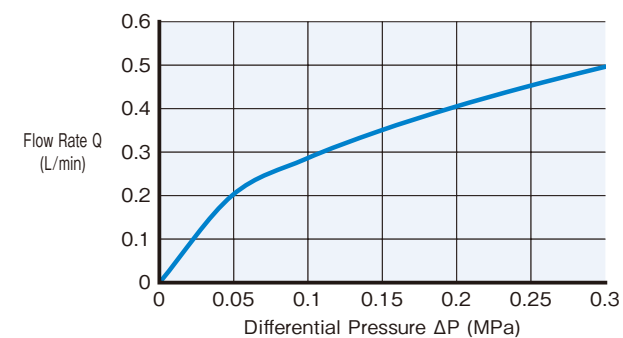

Flow Rate Cv:0.014

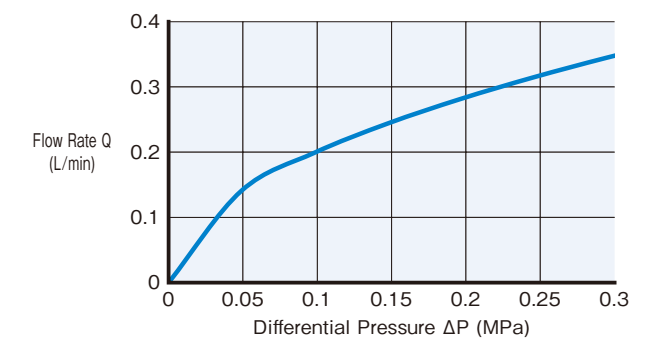

Corrosion-resistant Solenoid Valve

NAVR-1*1*



Specifications

Model Code	NAVR-121*	NAVR-161*	NAVR-131*
Structure	2-way(Normally Closed)	2-way(Normally Open)	3-way
Orifice Size	φ1.2 Equivalency [mm]		
Connection Size	M6 P=1.0		
Cv	0.04		
Applicable Media	DI Water, Corrosive Fluid		
Media Pressure	IN: 0~200kPa OUT: 0~50kPa	IN: 0~200kPa OUT: 0~50kPa	COM: -50~100kPa NO,NC: 0~50kPa
Media Temperature	10~50°C		
Ambient Temperature	10~50°C		
Power Consumption	2.4W		
Coil Temperature Rise	60°C [degrees C (or less)]		
Insulation Class	Class B (JIS C 4003)		
Wetted Material	Valve Body: PTFE Diaphragm: PTFE+FFKM	Valve Body: PTFE Diaphragm: PTFE+FFKM	Valve Body: PTFE Diaphragm: PTFE+FFKM Stem: Sapphire

*Specifications are subject to change without notice.

Model Selection Table

NAVR-1*1*

Voltage
1: DC 12V
2: DC 24V

Structure
2: 2-way (Normally Closed)
3: 3-way
6: 2-way (Normally Open)

Dimensional Drawing

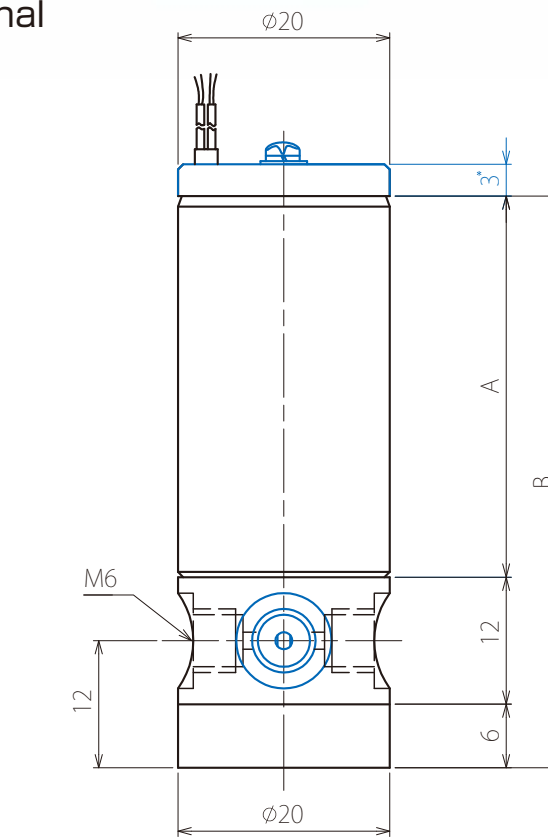

	A	B
AVH-121*	35	53
AVH-161*	36	54
AVH-131*		

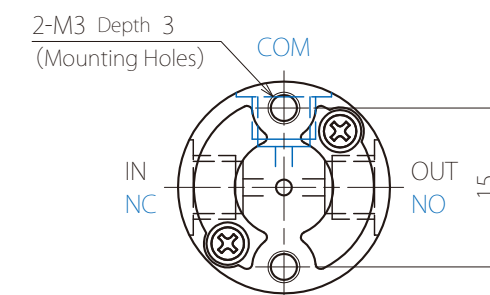

*Blue outlines represent 3-way valve and top portion (※) of normally open 2-way valve.

(unit : mm)

Flow Rate Cv:0.04

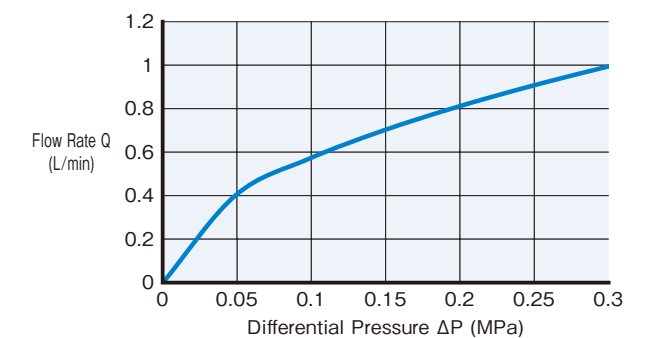

Corrosion-resistant Solenoid Valve

NAVR-2*1*



Specifications

Model Code	NAVR-221*	NAVR-261*	NAVR-231*
Structure	2-way(Normally Closed)	2-way(Normally Open)	3-way
Orifice Size	φ1.6 Equivalency [mm]		
Connection Size	M6 P=1.0		
Cv	0.05		
Applicable Media	DI Water, Corrosive Fluid		
Media Pressure	IN: -90~200kPa OUT: 0~50kPa	IN: -50~200kPa OUT: 0~50kPa	COM: -50~100kPa NO,NC: 0~50kPa
Media Temperature	10~50°C		
Ambient Temperature	10~50°C		
Power Consumption	3.0W		
Coil Temperature Rise	60°C [degrees C (or less)]		
Insulation Class	Class B (JIS C 4003)		
Wetted Material	Valve Body: PTFE Diaphragm: PTFE+FFKM	Valve Body: PTFE Diaphragm: PTFE+FFKM	Valve Body: PTFE Diaphragm: PTFE+FFKM Stem: Sapphire

*Specifications are subject to change without notice.

Model Selection Table

NAVR-2*1*

Voltage
1: DC 12V
2: DC 24V

Structure
2: 2-way (Normally Closed)
3: 3-way
6: 2-way (Normally Open)

Dimensional Drawing

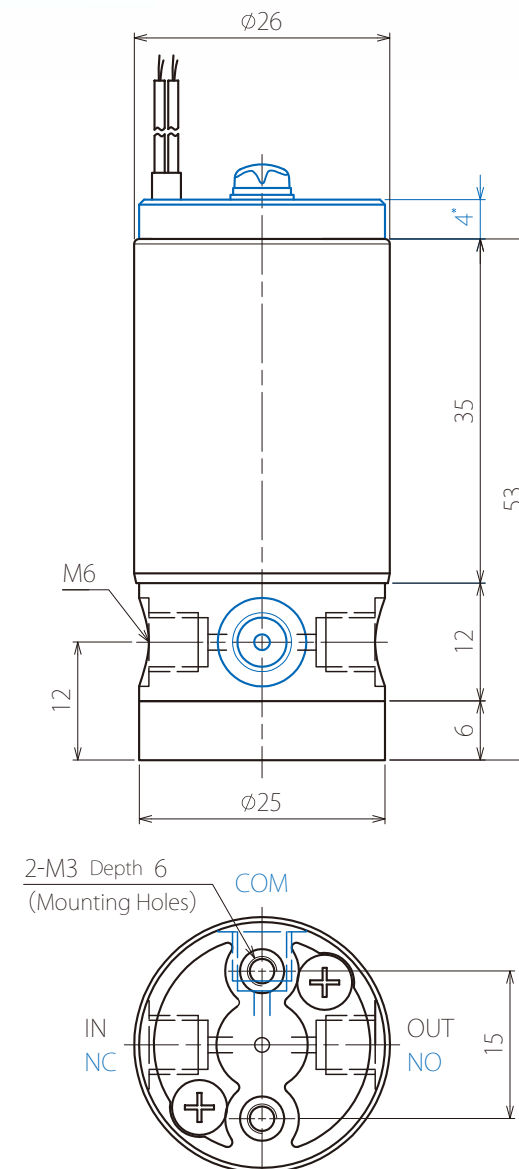

Blue outlines represent 3-way valve and top portion () of normally open 2-way valve.

(unit : mm)

Flow Rate Cv:0.05

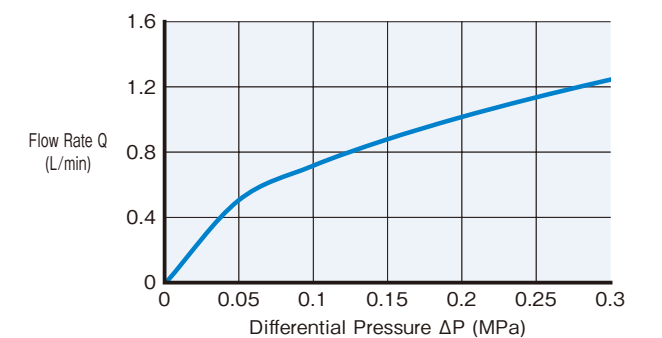

Corrosion-resistant Solenoid Valve

NAVR-3*3*



Specifications

Model Code	NAVR-323*	NAVR-363*	NAVR-333*
Structure	2-way(Normally Closed)	2-way(Normally Open)	3-way
Orifice Size	φ3.0 Equivalency [mm]		
Connection Size	Rc1/8		
Cv	0.13		
Applicable Media	DI Water, Corrosive Fluid		
Media Pressure	IN: -50~200kPa OUT: 0~50kPa	IN: -50~200kPa OUT: 0~50kPa	COM: -50~150kPa NO,NC: 0~50kPa
Media Temperature	10~50°C		
Ambient Temperature	10~50°C		
Power Consumption	4.0W		
Coil Temperature Rise	60°C [degrees C (or less)]		
Insulation Class	Class B (JIS C 4003)		
Wetted Material	Valve Body: PTFE Diaphragm: PTFE+FFKM	Valve Body: PTFE Diaphragm: PTFE+FFKM	Valve Body: PTFE Diaphragm: PTFE+FFKM Stem: Sapphire

*Specifications are subject to change without notice.

Model Selection Table

NAVR-3*3*

Voltage
1: DC 12V
2: DC 24V

Structure
2: 2-way (Normally Closed)
3: 3-way
6: 2-way (Normally Open)

Dimensional Drawing

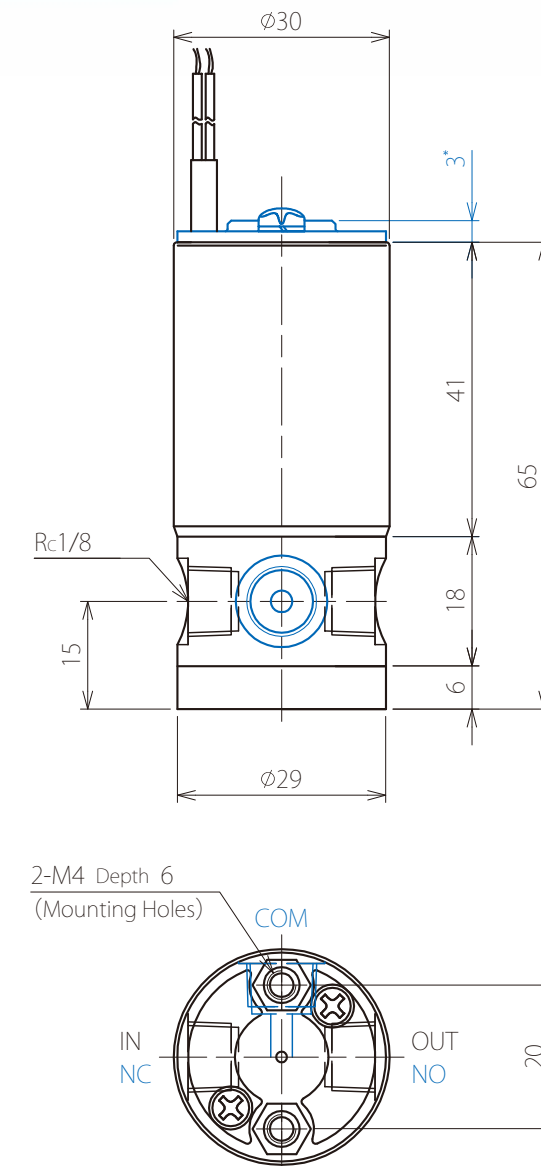

Blue outlines represent 3-way valve and top portion () of normally open 2-way valve.

(unit : mm)

Flow Rate Cv:0.13

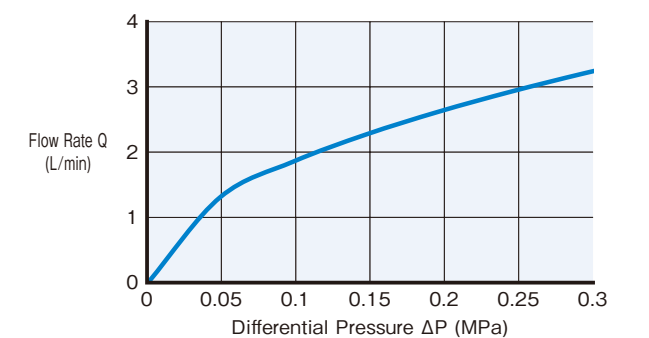

Corrosion-resistant Solenoid Valve

NAVR-4*4*



Dimensional Drawing

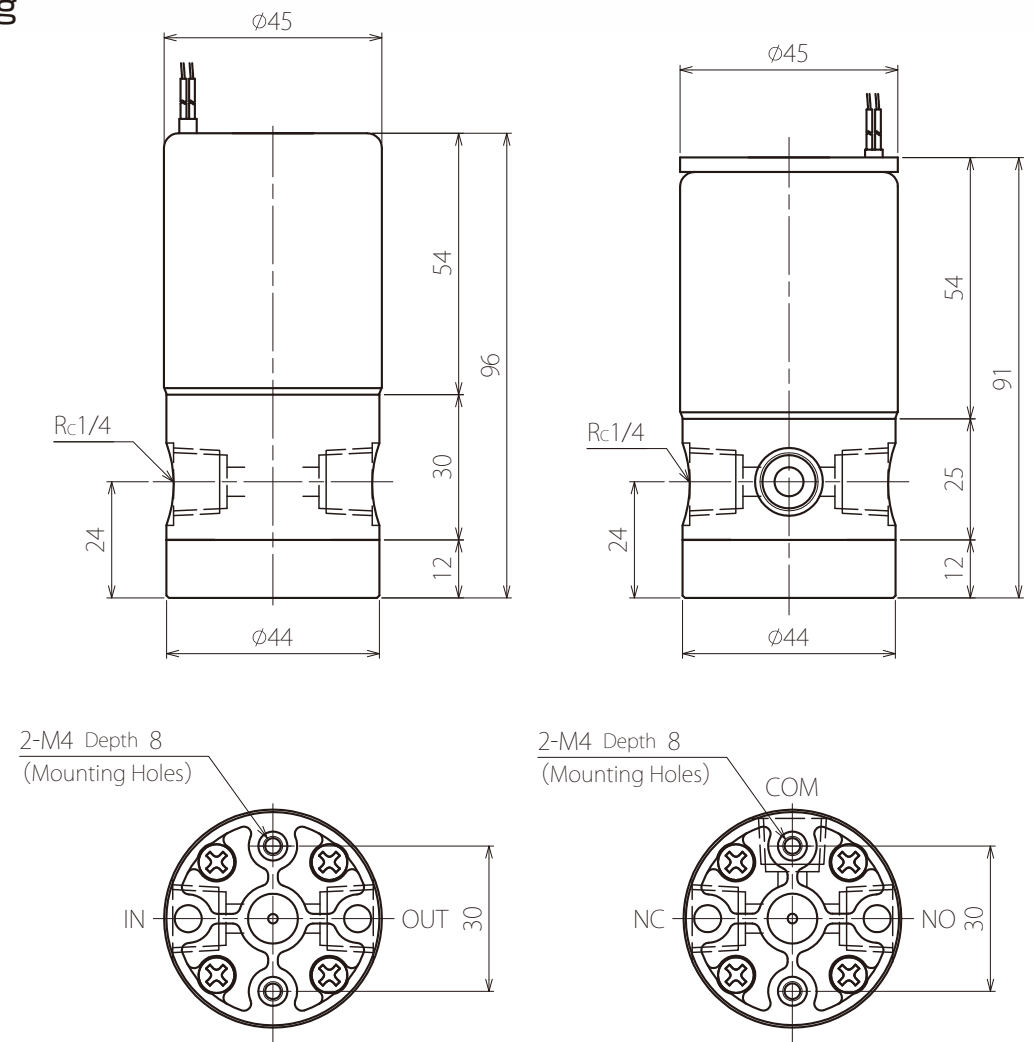

NAVR-424*

NAVR-434*

(unit : mm)

Specifications

Model Code	NAVR-424*	NAVR-434*
Structure	2-way (Normally Closed)	3-way
Orifice Size	φ5.0 Equivalency [mm]	
Connection Size	Rc1/4	
Cv	0.3	
Applicable Media	DI Water, Corrosive Fluid	
Media Pressure	IN: -90~200kPa OUT: 0~50kPa	COM: -90~200kPa NO,NC: 0~50kPa
Media Temperature	10~50°C	
Ambient Temperature	10~50°C	
Power Consumption	7.0W	
Coil Temperature Rise	60°C [degrees C (or less)]	
Insulation Class	Class B (JIS C 4003)	
Wetted Material	Valve Body: PTFE	Valve Body: PTFE
	Diaphragm: PTFE+FKM	Diaphragm: PTFE+FKM
	Stem: PCTFE	

*Specifications are subject to change without notice.

Model Selection Table

NAVR-4*4*

Voltage
1: DC 12V
2: DC 24V

Structure
2: 2-way (Normally Closed)
3: 3-way

Flow Rate Cv:0.3

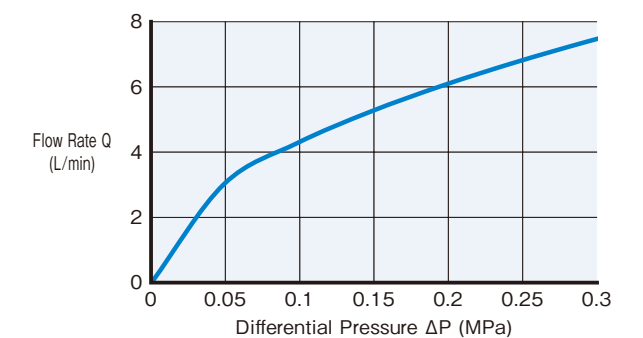

MEMO

MEMO