

ADVANCE[®]

PRODUCT CATALOG
Valves for a multiplicity of requirements

www.advance-e.jp

HICV series

Self-Control Valves

ADVANCE ELECTRIC CO., INC.

519-1, Urayashiki, Hazama-Cho, Kasugai-Shi, Aichi, 487-0031 Japan PHONE: +81-568-88-7300 FAX: +81-568-88-7373

www.advance-e.jp

INDEX



HICV series

Self Control Valves

HICV-045CBi*-131	02·03	HICV-110CBi*-131P	18·19
HICV-045CBi4-131 (Characteristics)	04·05	HICV-110CBi7-131P (Characteristics)	20·21
HICV-045CBi5/6-131 (Characteristics)	06·07	HICV-110CBi8-131P (Characteristics)	22·23
HICV-065CBi6-131P	08·09	HICV-130CBi*-131P	24·25
HICV-065CBi6-131P (Characteristics)	10·11	HICV-130CBi7-131P (Characteristics)	26·27
HICV-090CBi*-131P	12·13	HICV-130CBi8-131P (Characteristics)	28·29
HICV-090CBi6-131P (Characteristics)	14·15		
HICV-090CBi7-131P (Characteristics)	16·17		

Export Control

●Export control is aimed at preventing the proliferation of weapons of mass destruction and other sensitive items to countries and regions of security concern or terrorist organizations. Export transactions of goods and technology that have potential weapons of mass destruction (WMD)/ conventional weapons applications are regulated under laws and regulations.

●To ensure safety by maintaining international peace and security, a license may be required from governmental authorities in order to export or provide products or technologies within this catalog. The regulation for export of cargos and technologies is defined by the following four regimes as well as governmental authorities of each country.

Nuclear Suppliers Group (NSG)
Australia Group (AG)

Missile Technology Control Regime (MTCR)
Wassenaar Arrangement (WA)

●Be sure to comply with each country's export control laws and regulations when exporting or providing products or technologies within this catalog.

※Please contact us if you have any questions.

HICV series

Self Control Valve

The HICV series of control valves achieve constant pressure stability on the downstream regardless of pressure fluctuations from the upstream. The downstream pressure is managed by the pilot air pressure supplied to the HICV.



Self Control Valve

HICV-045CBi*-131



Specifications

Model Code	See Model Selection Table
Orifice Size	φ7 Equivalency [mm]
Connection Size	See Model Selection Table
Recommended Flow Range	4: 0.4~2[L/min] H ₂ O
	5: 1~5[L/min] H ₂ O
	6: 1~5[L/min] H ₂ O
	<small>*The adjustable flow range differs according to the downstream restriction.</small>
Applicable Media	DI Water, Corrosive Fluid
Media Pressure	IN: 0~0.5MPa
	OUT: 0~0.5MPa
Media Temperature	10~90°C
Ambient Temperature	0~40°C
Operational Mode	Single Pilot Type
Pneumatic Pressure	0.1~0.3MPa
Wetted Material	Diaphragm: PTFE
	Valve Body: PTFE

*Specifications are subject to change without notice.

Model Selection Table

HICV-045CBi*-131

Connection Size
 4: (I.D.×O.D.) 3.97×6.35 [mm]
 5: (I.D.×O.D.) 6.35×9.53 [mm]
 6: (I.D.×O.D.) 9.53×12.7 [mm]

Dimensional Drawing

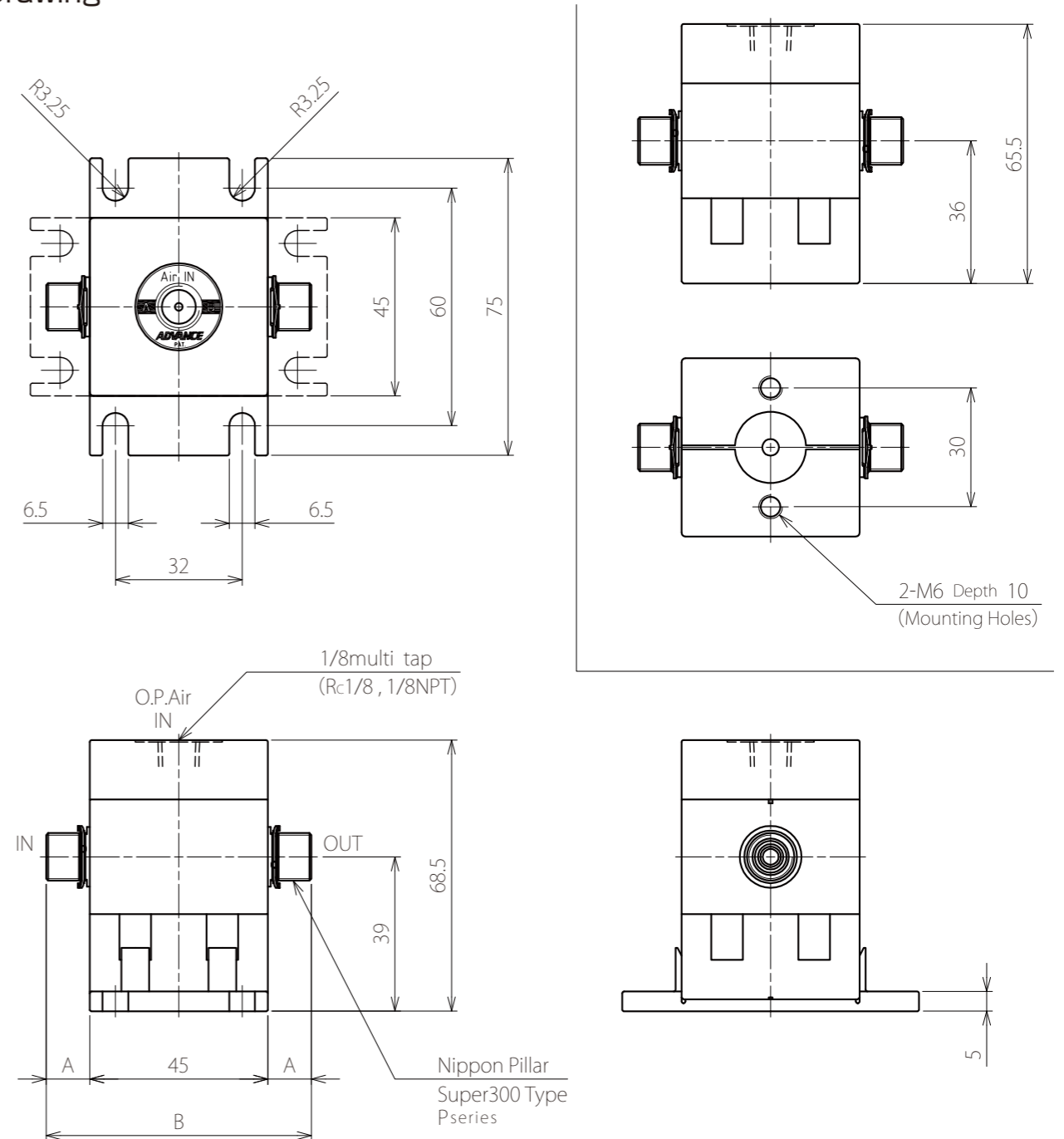

Model Code	Connection	A	B
HICV-045CBi4-131	3.97×6.35	11	67
HICV-045CBi5-131	6.35×9.53	15	75
HICV-045CBi6-131	9.53×12.7	17.5	80

(unit : mm)

HICV-045CBi4-131 (Characteristics)

Measurement Method | A fixed orifice with a size of 1.5mm installed on the downstream of test unit.

Fig.1 Outlet Pressure vs Inlet Pressure

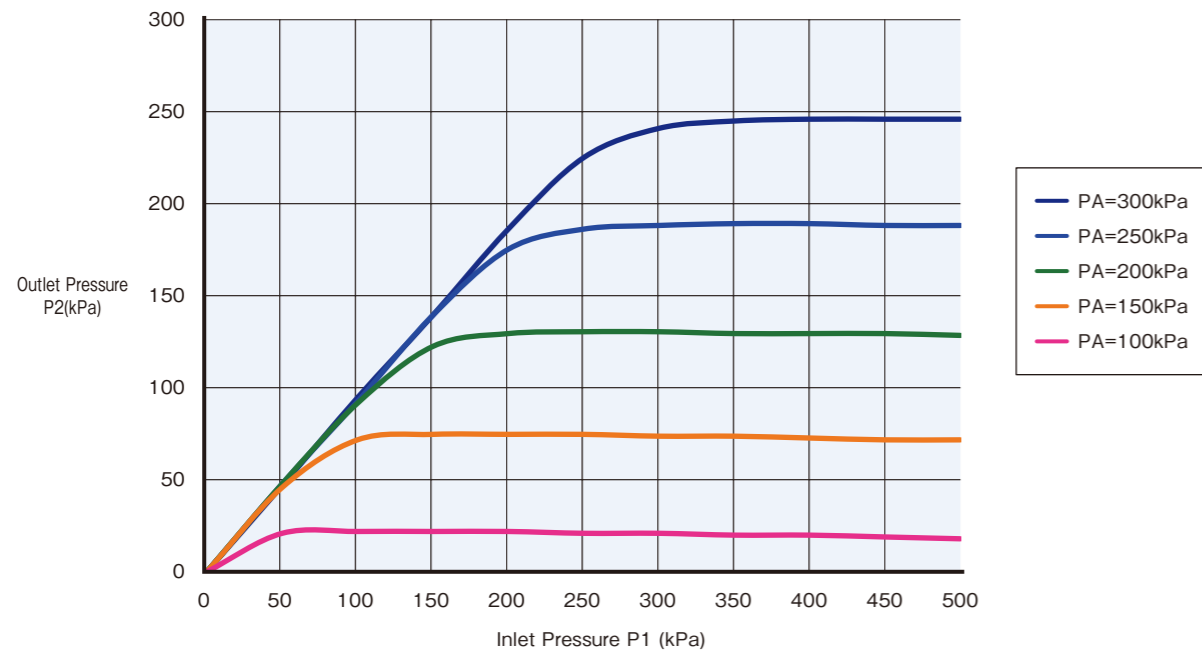
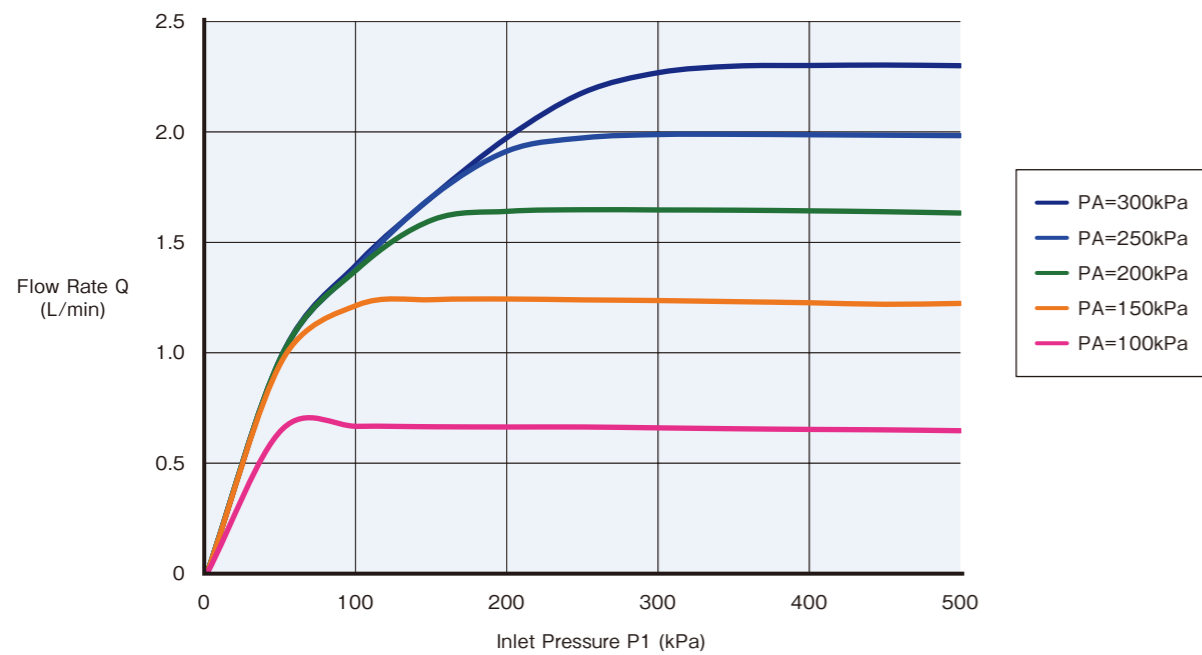

Fig.2 Flow Rate vs Inlet Pressure



Measurement Method | Inlet Pressure P1=500[kPa]

Fig.3 Outlet Pressure vs Pneumatic Pressure

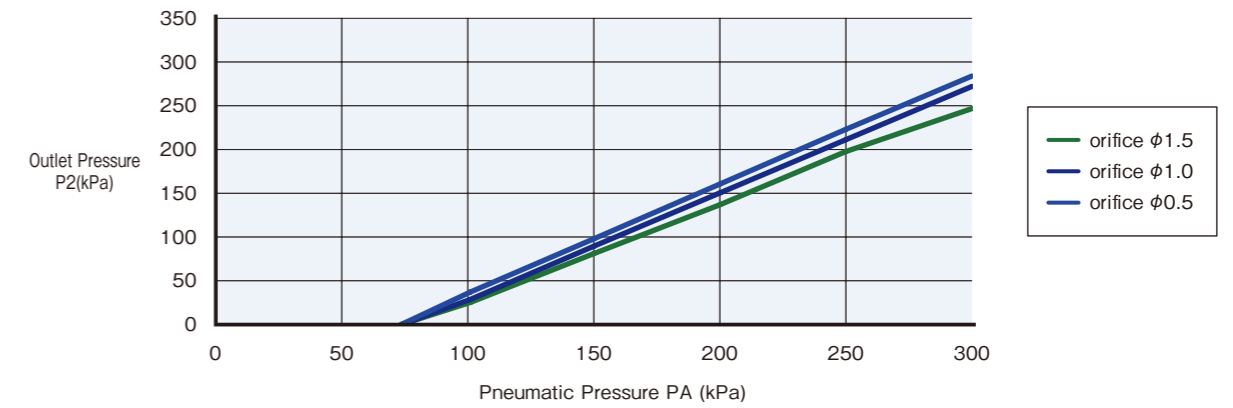

Fig.4 Flow Rate vs Pneumatic Pressure

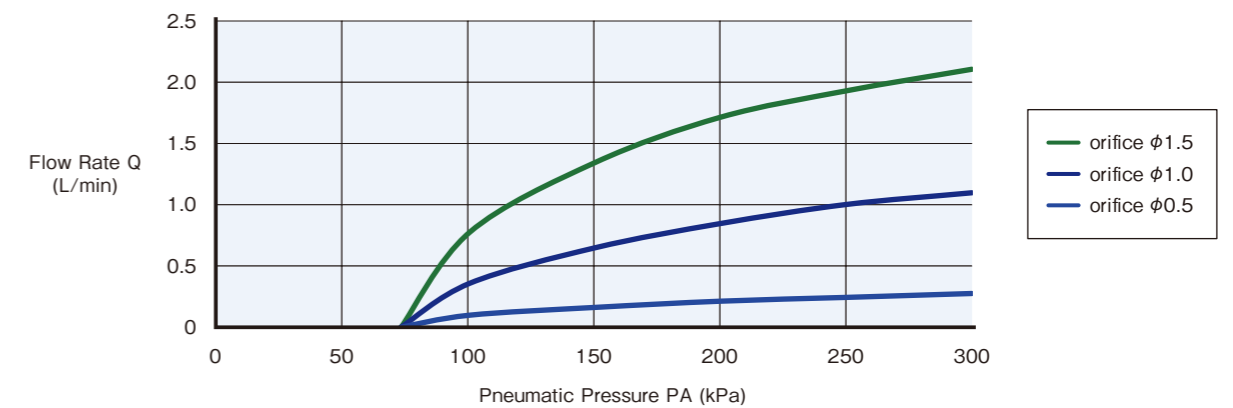
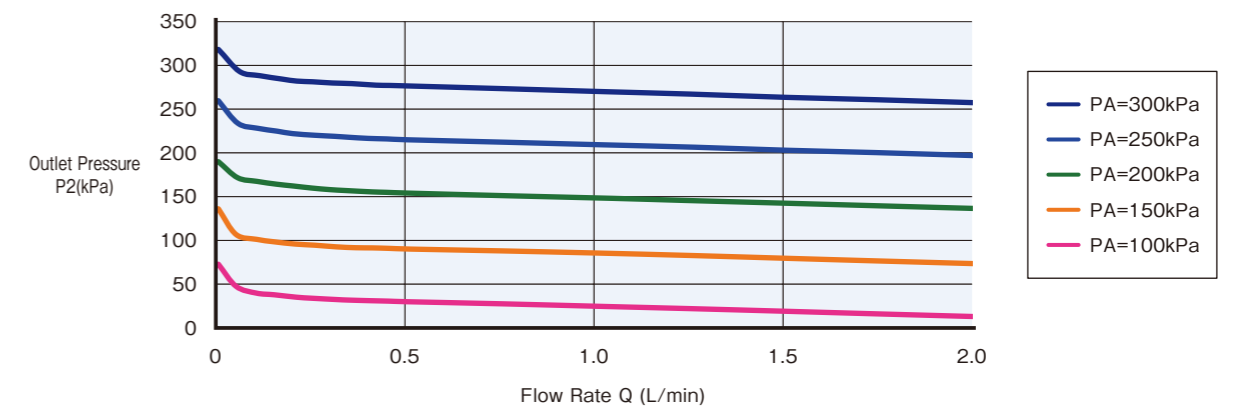

Fig.5 Outlet Pressure vs Flow Rate



HICV-045CBi5/6-131 (Characteristics)

Measurement Method | A fixed orifice with a size of 2.5mm installed on the downstream of test unit.

Fig.1 Outlet Pressure vs Inlet Pressure

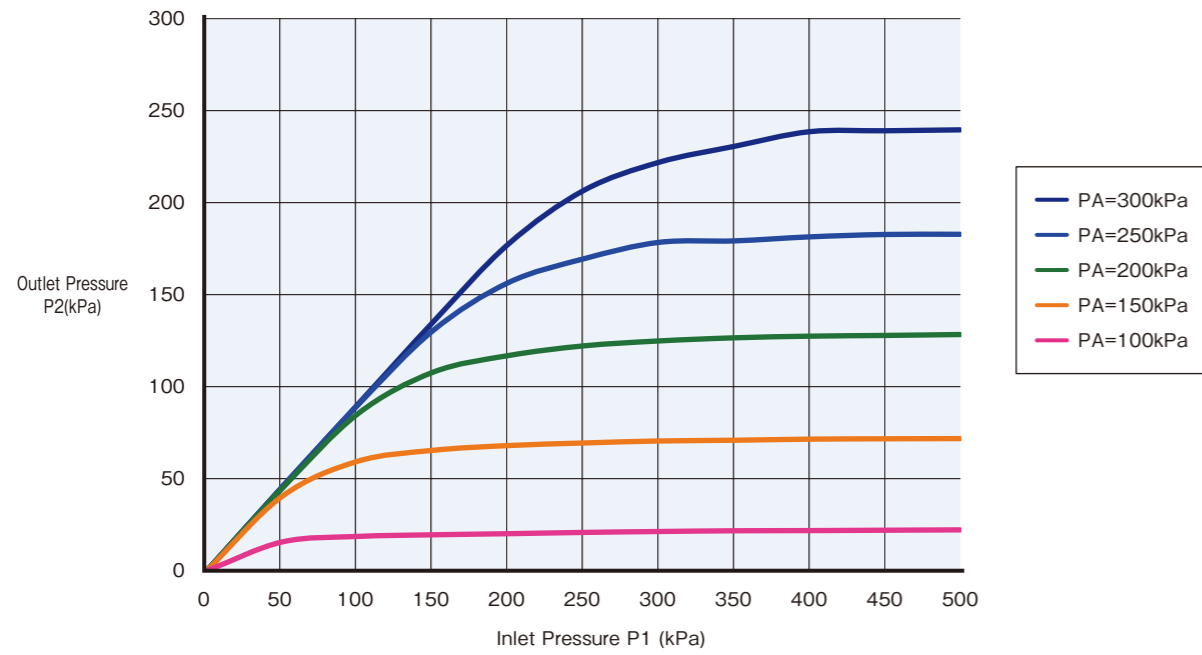
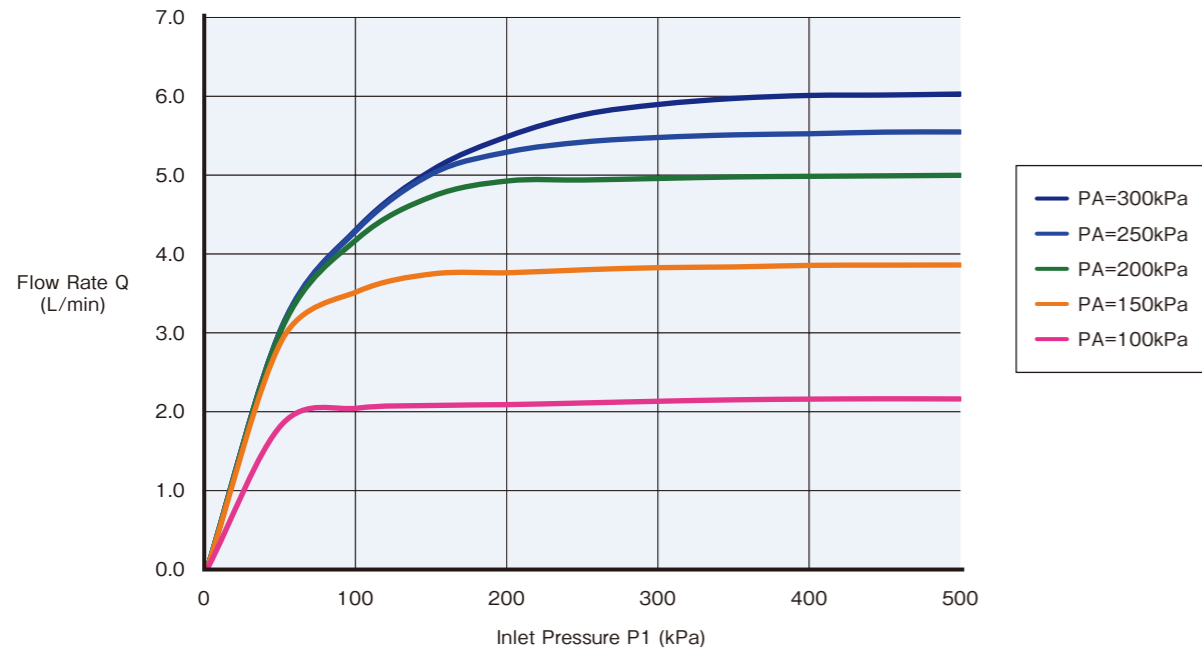

Fig.2 Flow Rate vs Inlet Pressure



Measurement Method | Inlet Pressure P1=500[kPa]

Fig.3 Outlet Pressure vs Pneumatic Pressure

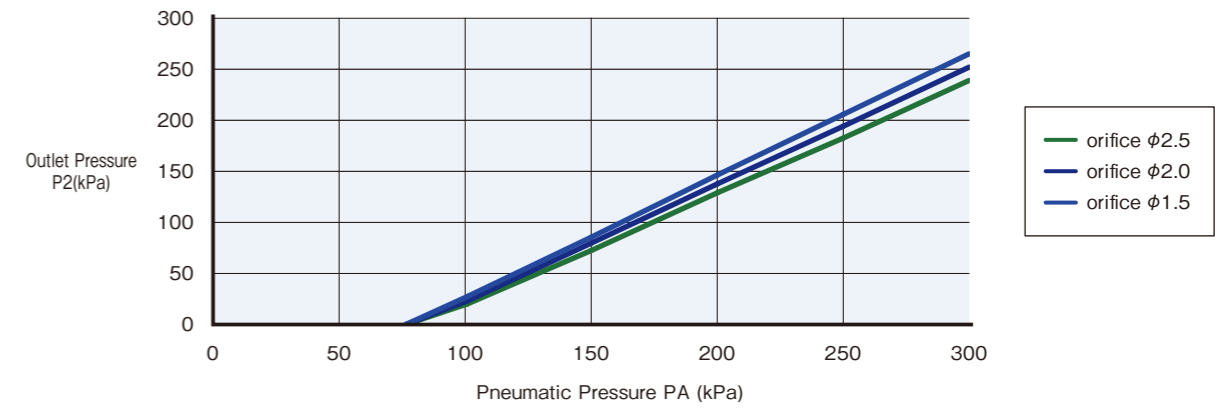

Fig.4 Flow Rate vs Pneumatic Pressure

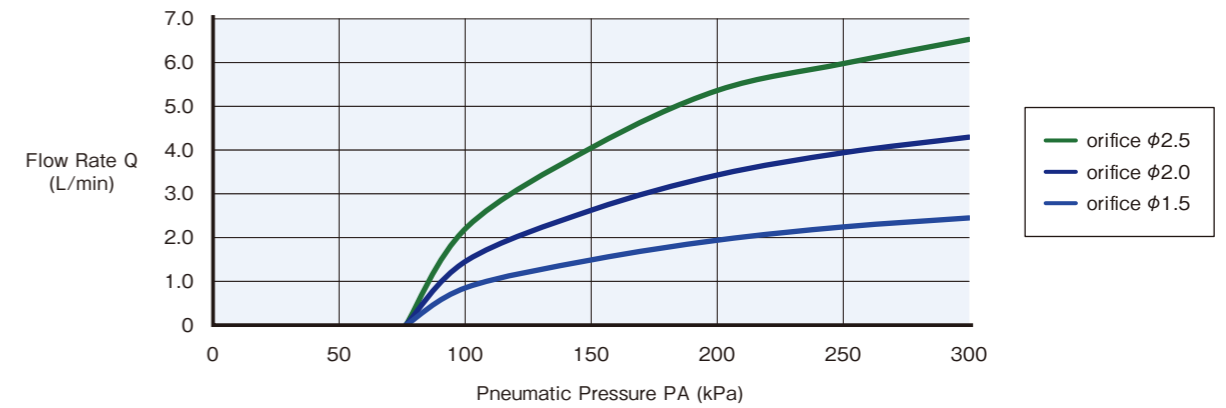
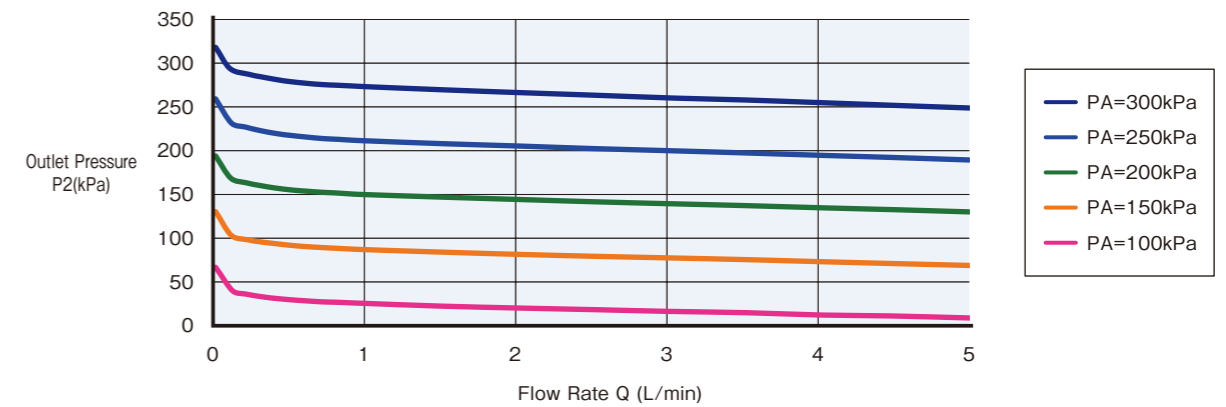

Fig.5 Outlet Pressure vs Flow Rate



Self Control Valve

HICV-065CBi6-131P



Specifications

Model Code	HICV-065CBi6-131P
Orifice Size	φ9.6 Equivalency [mm]
Connection Size	(I.D.×O.D.)9.53×12.7 [mm]
Recommended Flow Range	2~10 [L/min] H ₂ O ※ The adjustable flow range differs according to the downstream restriction.
Applicable Media	DI Water, Corrosive Fluid
Media Pressure	IN: 0~0.5MPa OUT: 0~0.5MPa
Media Temperature	10~90°C
Ambient Temperature	0~40°C
Operational Mode	Single Pilot Type
Pneumatic Pressure	0.1~0.3MPa
Wetted Material	Diaphragm: PTFE
	Valve Body: PTFE
	Seat Stem: PTFE
	Stay: PTFE

※ Specifications are subject to change without notice.

Model Selection Table

HICV-065CBi6-131P

Dimensional Drawing

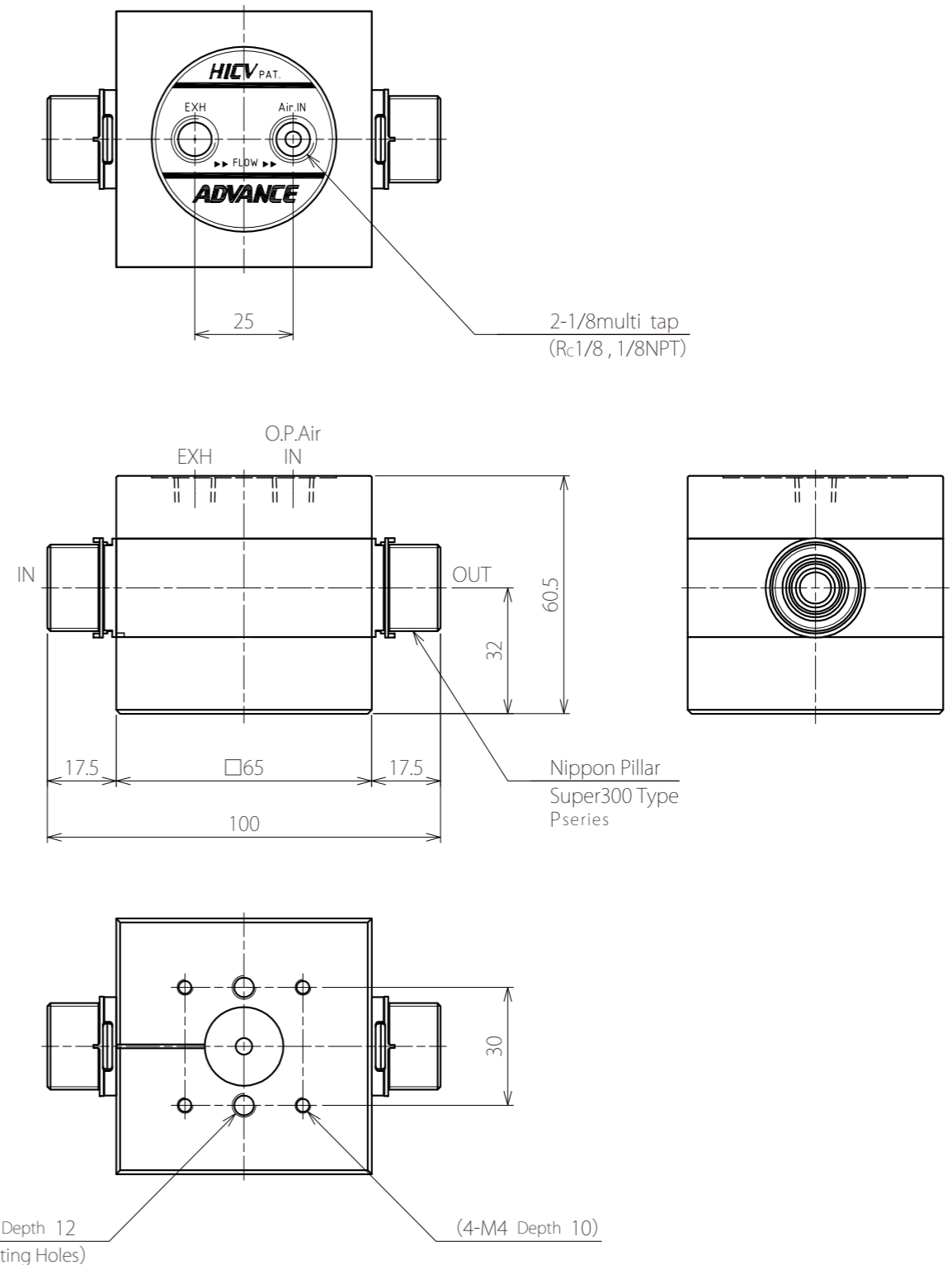

(unit : mm)

HICV-065CBi6-131P(Characteristics)

Measurement Method | A fixed orifice with a size of 4.0mm installed on the downstream of test unit.

Fig.1 Outlet Pressure vs Inlet Pressure

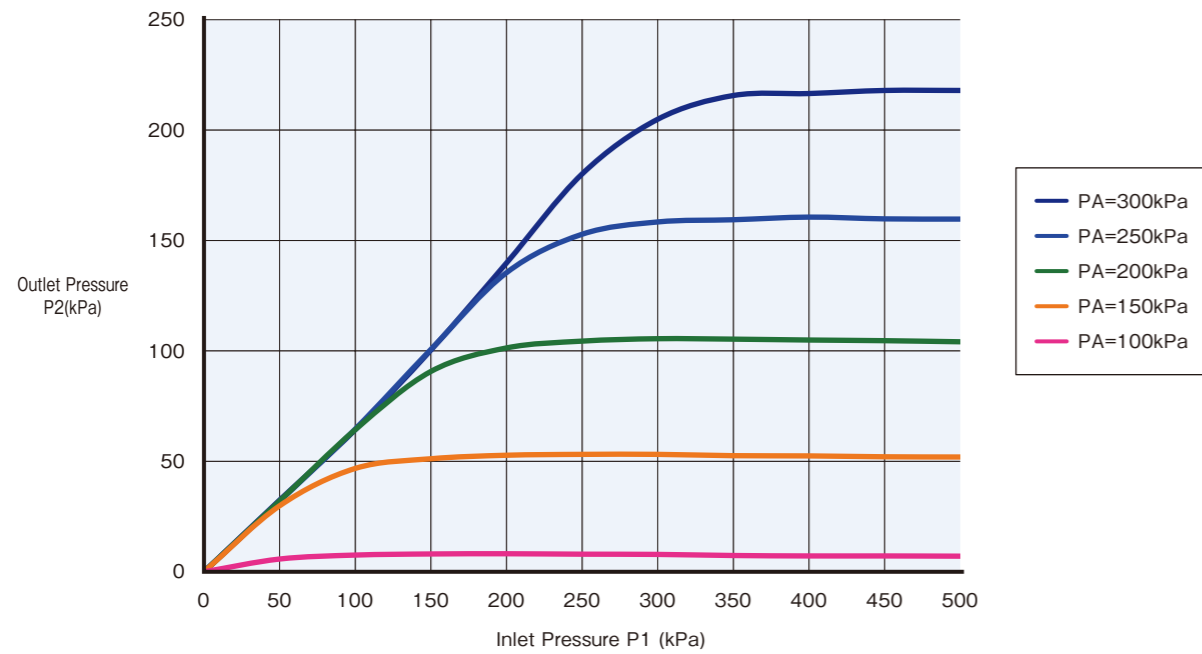
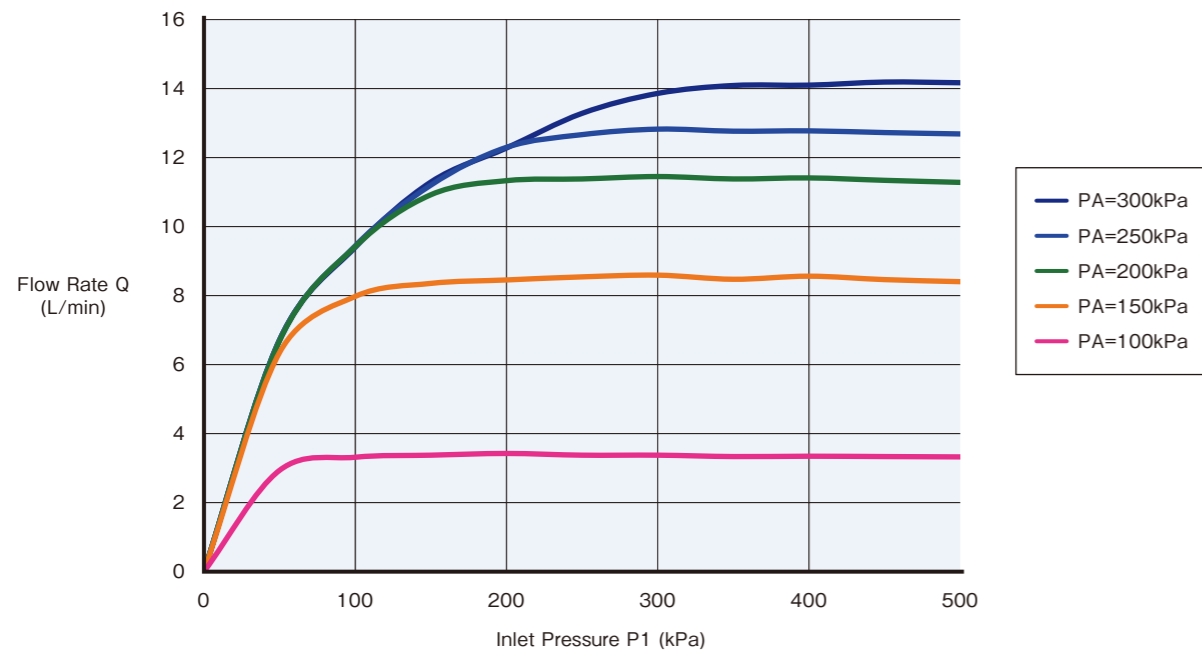

Fig.2 Flow Rate vs Inlet Pressure



Measurement Method | Inlet Pressure P1=500[kPa]

Fig.3 Outlet Pressure vs Pneumatic Pressure

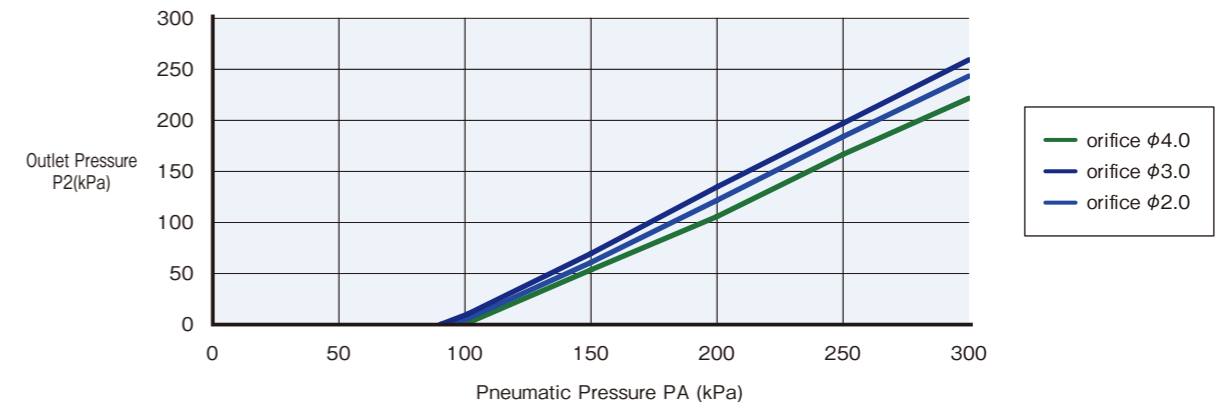

Fig.4 Flow Rate vs Pneumatic Pressure

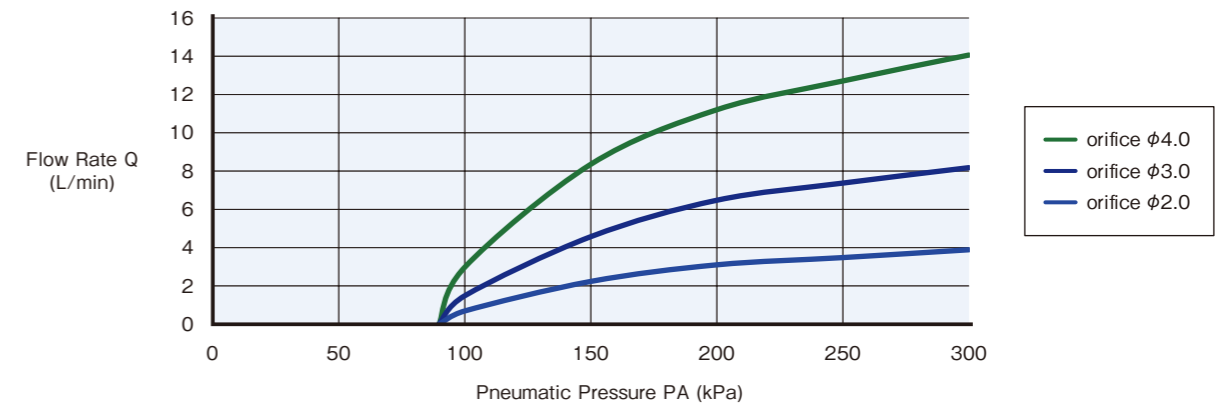
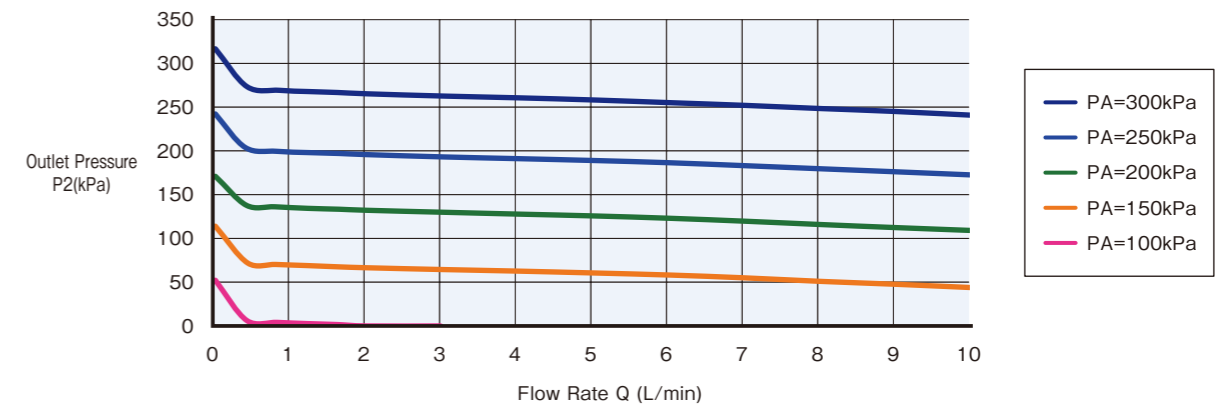

Fig.5 Outlet Pressure vs Flow Rate



Self Control Valve

HICV-090CBi*-131P



Dimensional Drawing

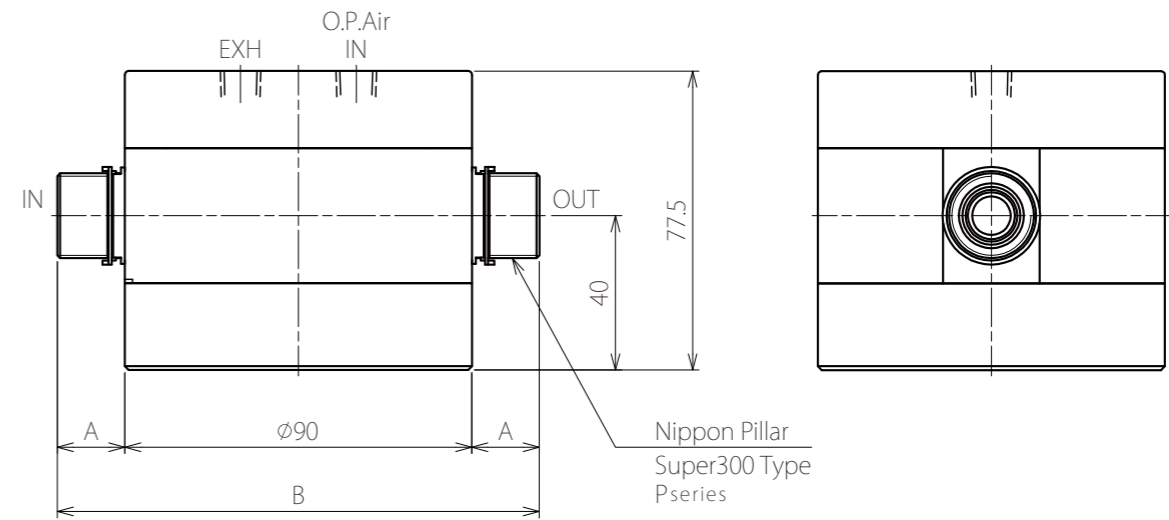
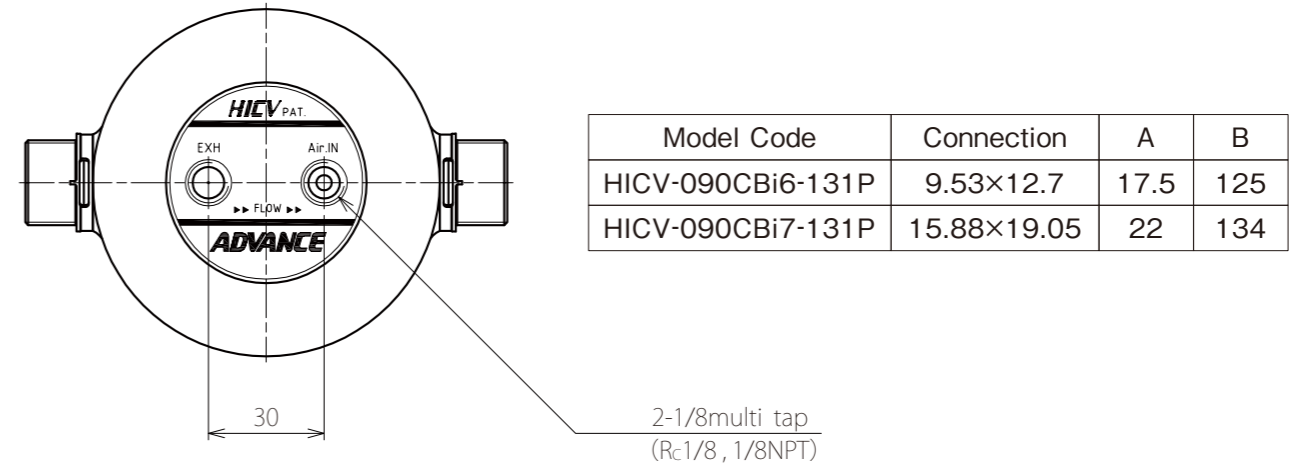

Specifications

Model Code	See Model Selection Table
Orifice Size	φ12 Equivalency [mm]
Connection Size	See Model Selection Table
Recommended Flow Range	5~20 [L/min] H ₂ O ※ The adjustable flow range differs according to the downstream restriction.
Applicable Media	DI Water, Corrosive Fluid
Media Pressure	IN: 0~0.5MPa OUT: 0~0.5MPa
Media Temperature	10~90°C
Ambient Temperature	0~40°C
Operational Mode	Single Pilot Type
Pneumatic Pressure	0.1~0.3MPa
Wetted Material	Diaphragm: PTFE
	Valve Body: PTFE
	Seat Stem: PTFE
	Stay: PTFE

※ Specifications are subject to change without notice.

Model Selection Table

HICV-090CBi*-131P

Connection Size
6: (I.D.×O.D.) 9.53×12.7 [mm]
7: (I.D.×O.D.) 15.88×19.05 [mm]

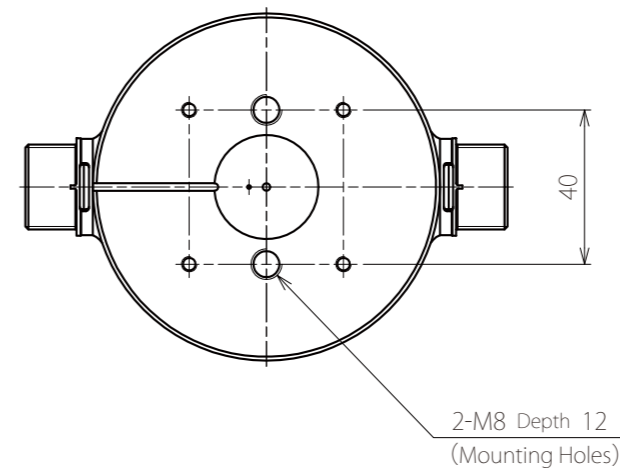

(unit : mm)

HICV-090CBi6-131P(Characteristics)

Measurement Method | A fixed orifice with a size of 5.0mm installed on the downstream of test unit.

Fig.1 Outlet Pressure vs Inlet Pressure

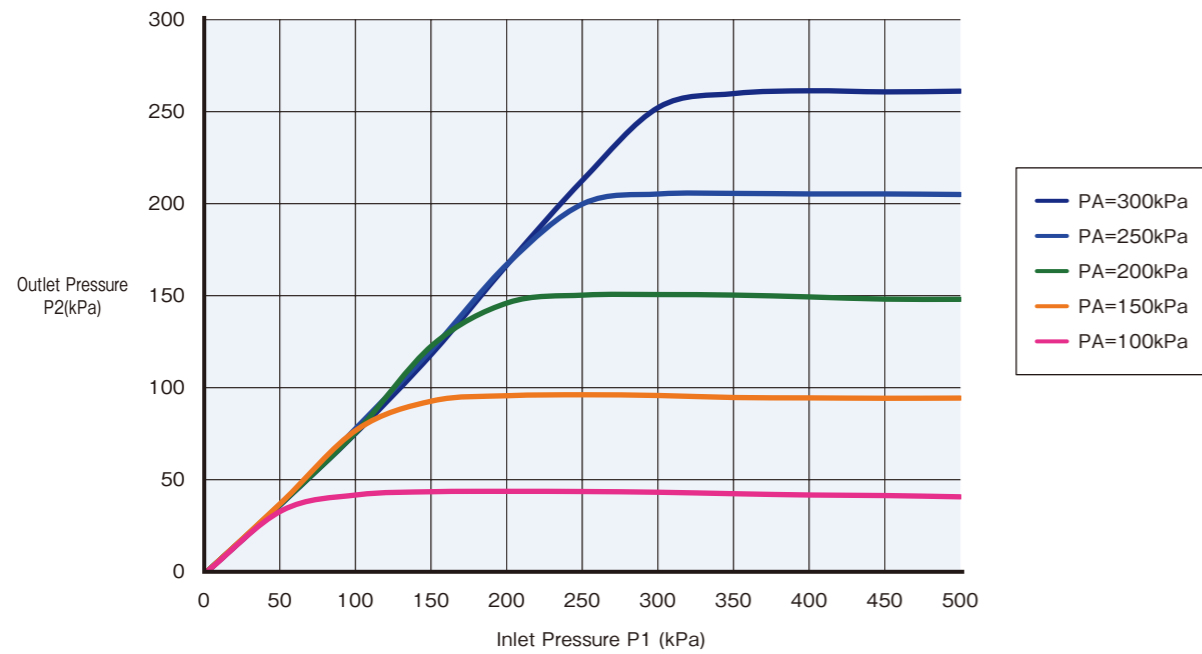
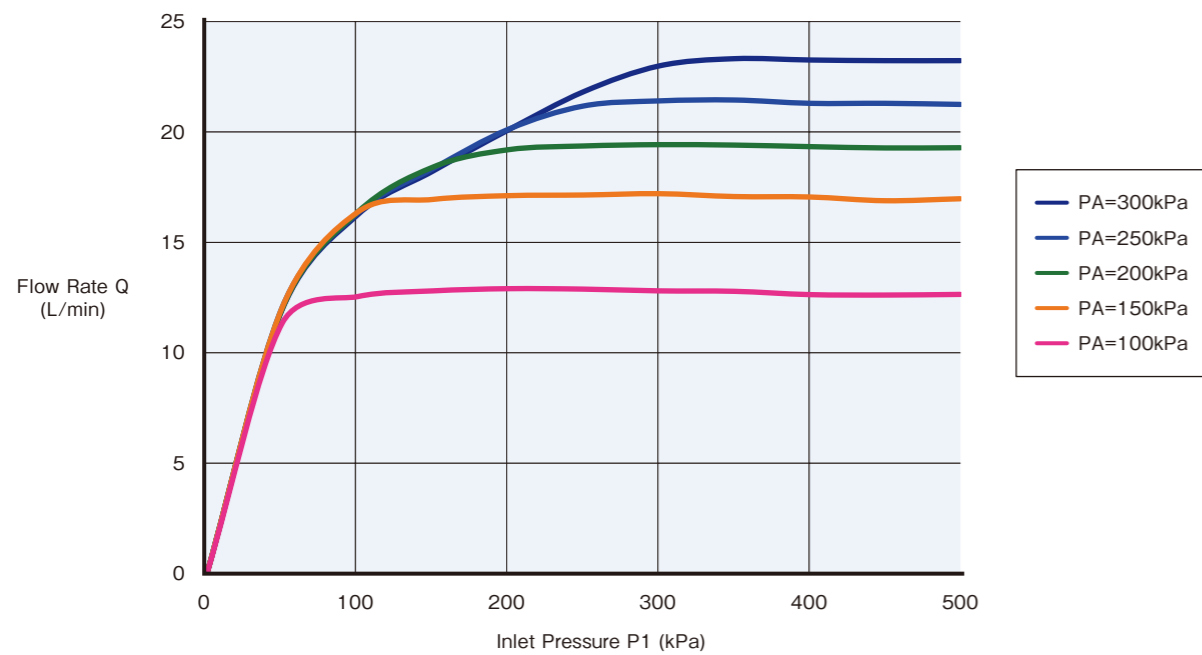

Fig.2 Flow Rate vs Inlet Pressure



Measurement Method | Inlet Pressure P1=500[kPa]

Fig.3 Outlet Pressure vs Pneumatic Pressure

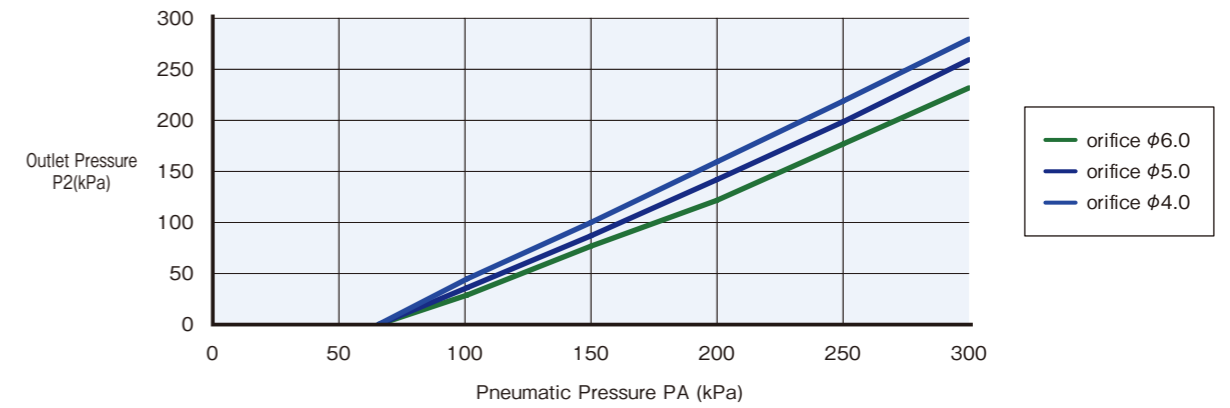

Fig.4 Flow Rate vs Pneumatic Pressure

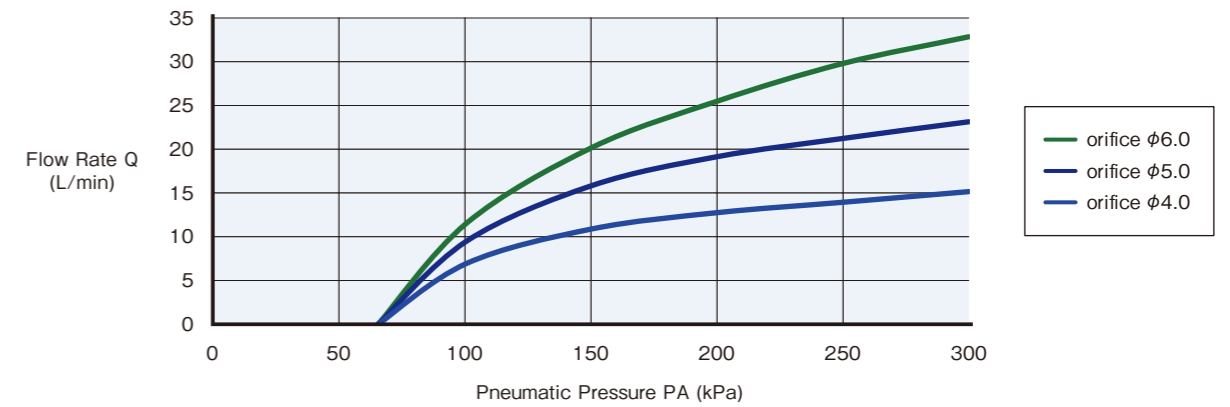
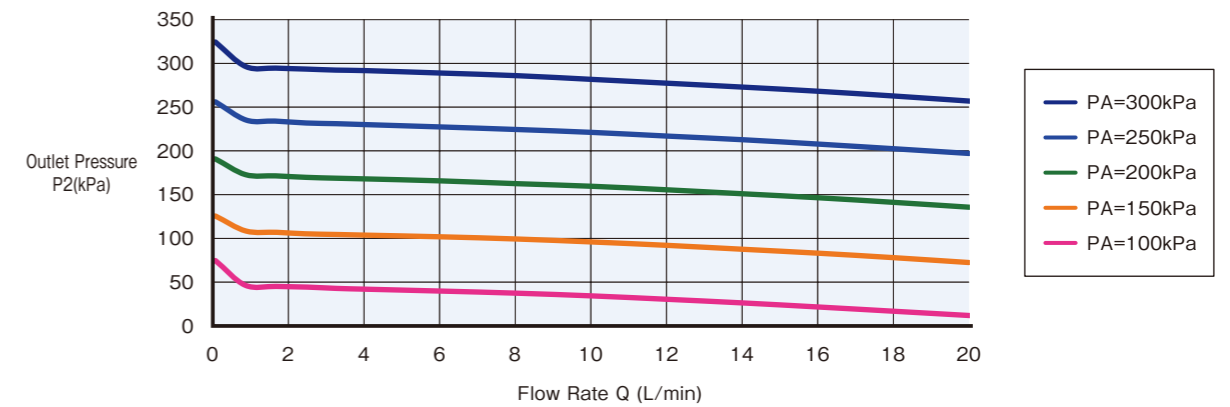

Fig.5 Outlet Pressure vs Flow Rate



HICV-090CBi7-131P(Characteristics)

Measurement Method A fixed orifice with a size of 6.0mm installed on the downstream of test unit.

Fig.1 Outlet Pressure vs Inlet Pressure

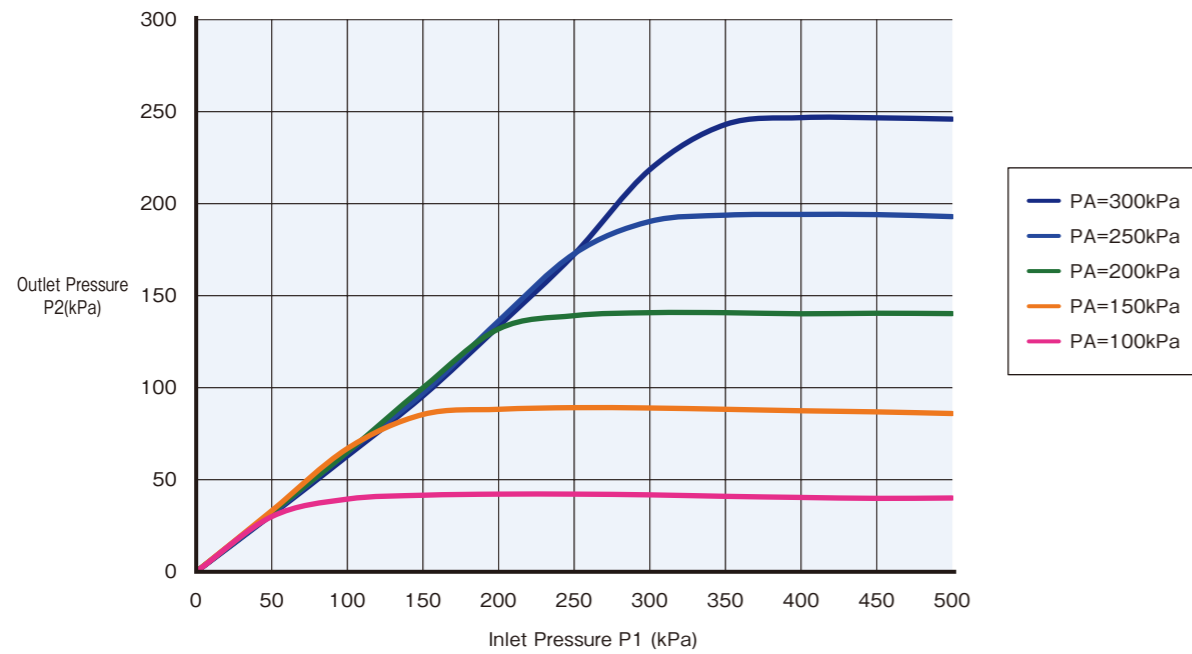
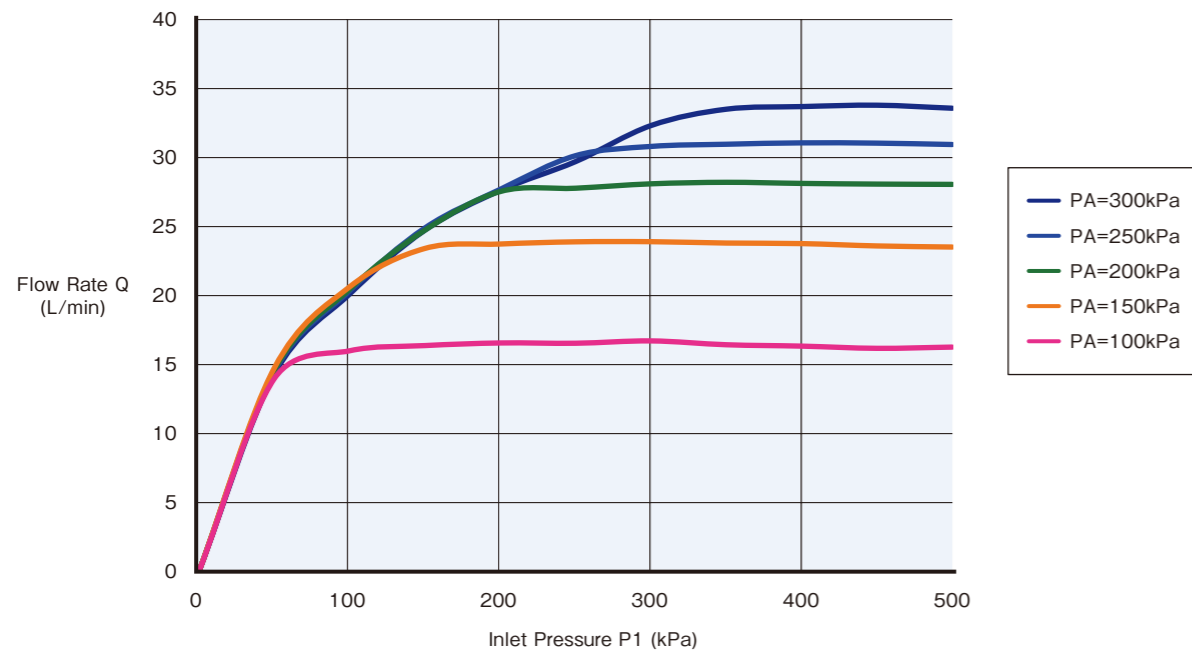

Fig.2 Flow Rate vs Inlet Pressure



Measurement Method Inlet Pressure P1=500 [kPa]

Fig.3 Outlet Pressure vs Pneumatic Pressure

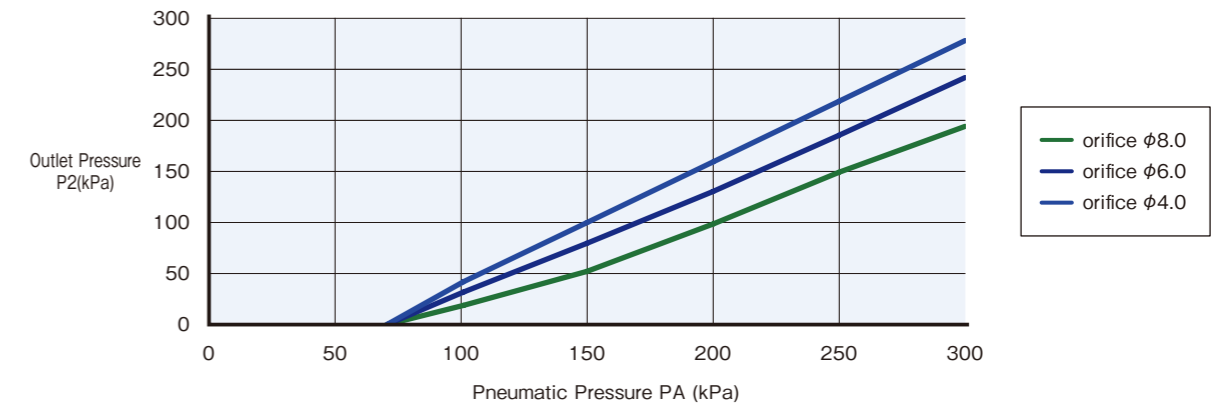

Fig.4 Flow Rate vs Pneumatic Pressure

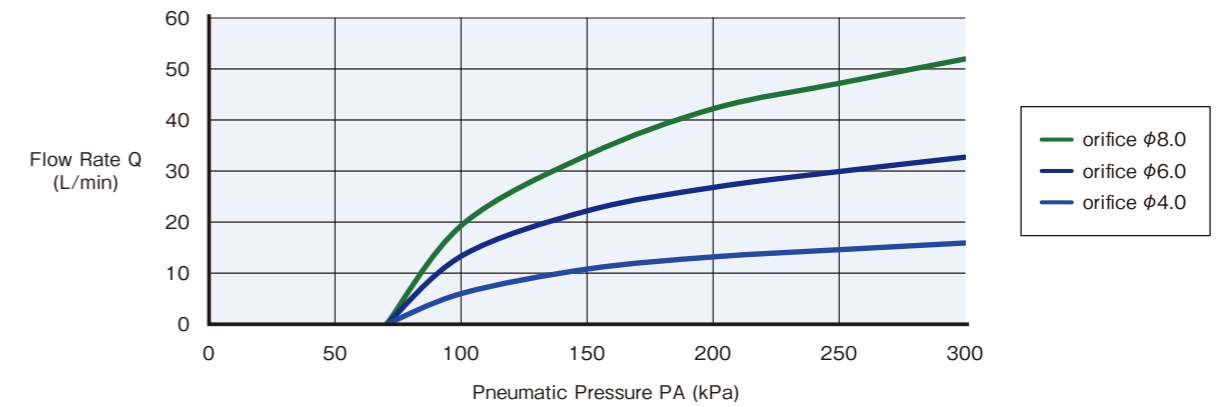
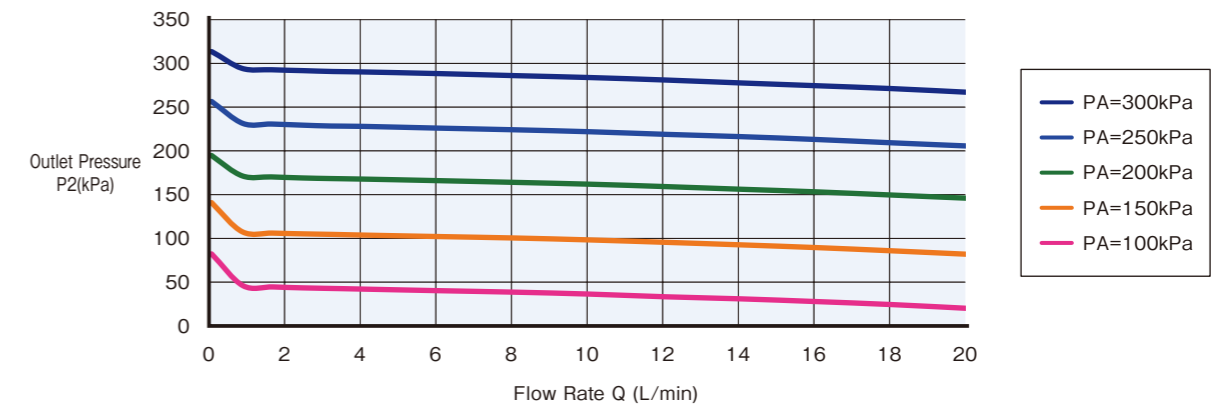

Fig.5 Outlet Pressure vs Flow Rate



Self Control Valve

HICV-110CBi*-131P



Specifications

Model Code	See Model Selection Table
Orifice Size	φ18.9 Equivalency [mm]
Connection Size	See Model Selection Table
Recommended Flow Range	10~30 [L/min] H ₂ O ※ The adjustable flow range differs according to the downstream restriction.
Applicable Media	DI Water, Corrosive Fluid
Media Pressure	IN: 0~0.5MPa OUT: 0~0.5MPa
Media Temperature	10~90°C
Ambient Temperature	0~40°C
Operational Mode	Single Pilot Type
Pneumatic Pressure	0.1~0.3MPa
Wetted Material	Diaphragm: PTFE
	Valve Body: PTFE
	Seat Stem: PTFE
	Stay: PTFE

※ Specifications are subject to change without notice.

Model Selection Table

HICV-110CBi*-131P

Connection Size
7: (I.D.XO.D.) 15.88×19.05 [mm]
8: (I.D.XO.D.) 22.23×25.4 [mm]

Dimensional Drawing

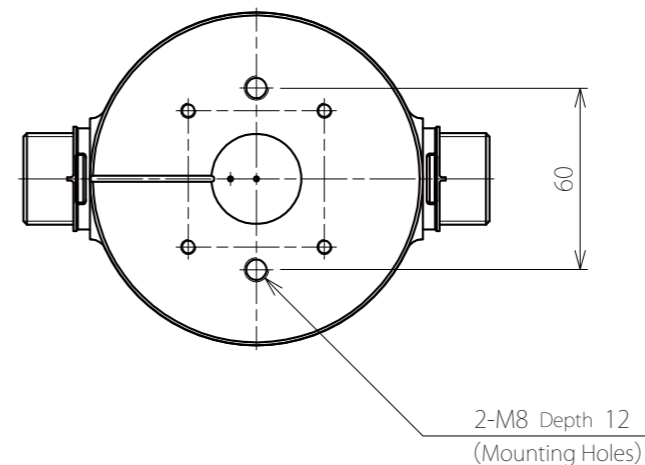
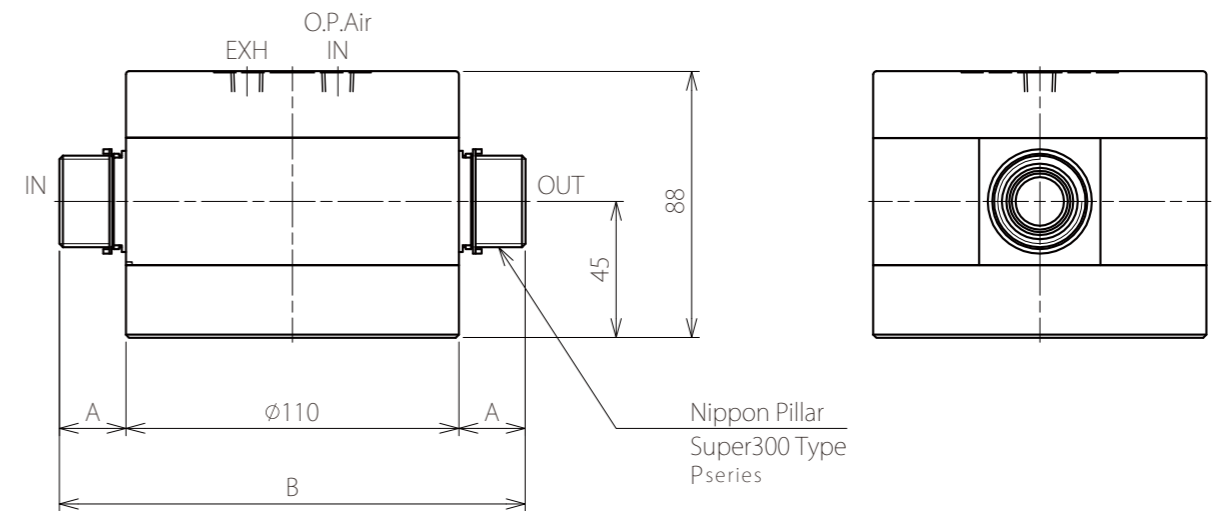
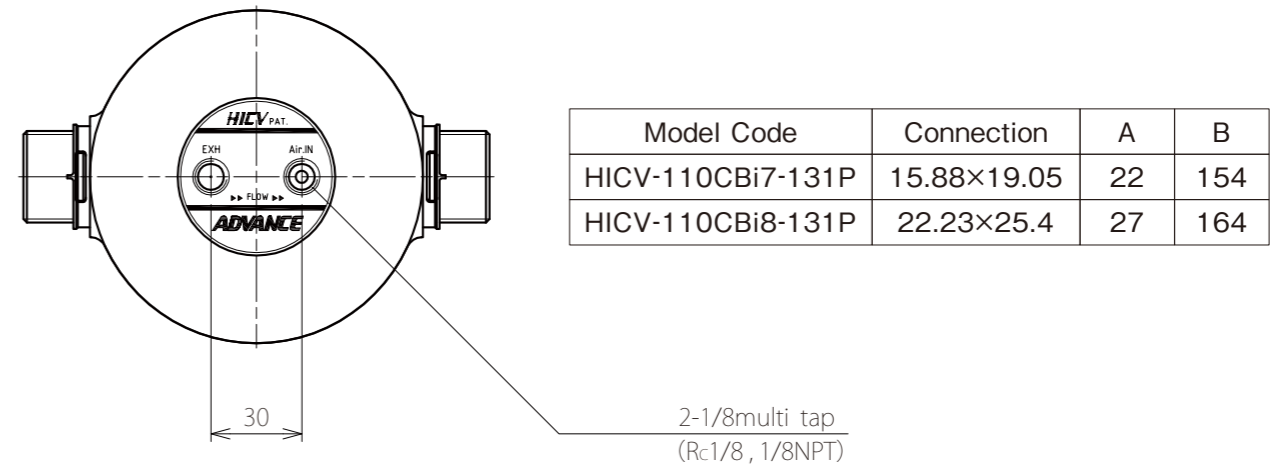

(unit : mm)

HICV-110CBi7-131P(Characteristics)

Measurement Method | A fixed orifice with a size of 6.0mm installed on the downstream of test unit.

Fig.1 Outlet Pressure vs Inlet Pressure

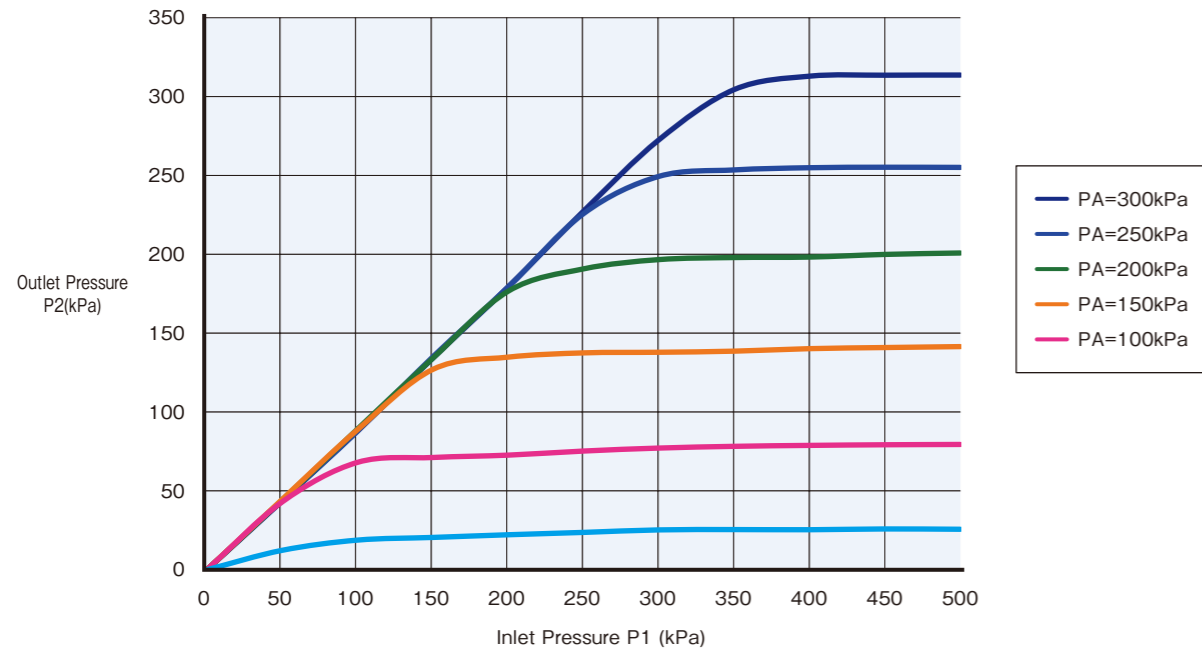
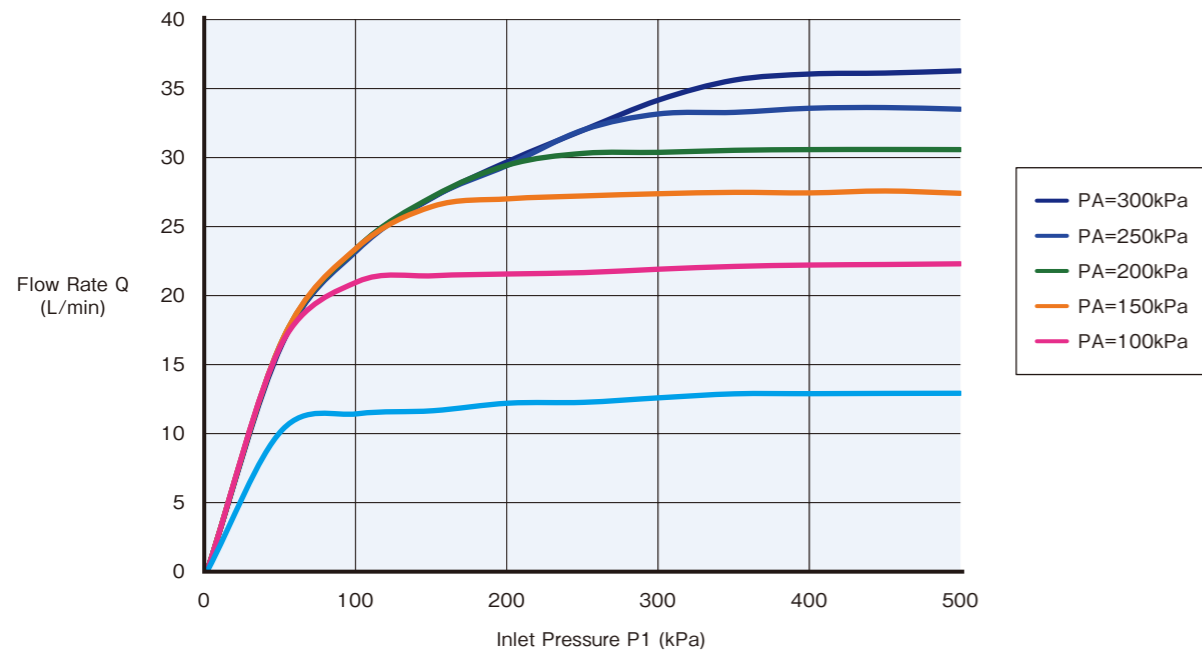

Fig.2 Flow Rate vs Inlet Pressure



Measurement Method | Inlet Pressure P1=500[kPa]

Fig.3 Outlet Pressure vs Pneumatic Pressure

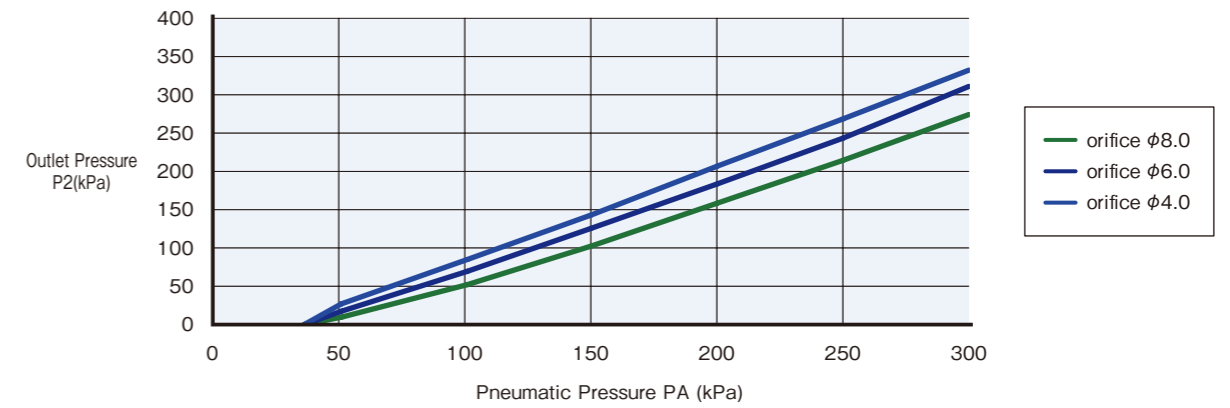

Fig.4 Flow Rate vs Pneumatic Pressure

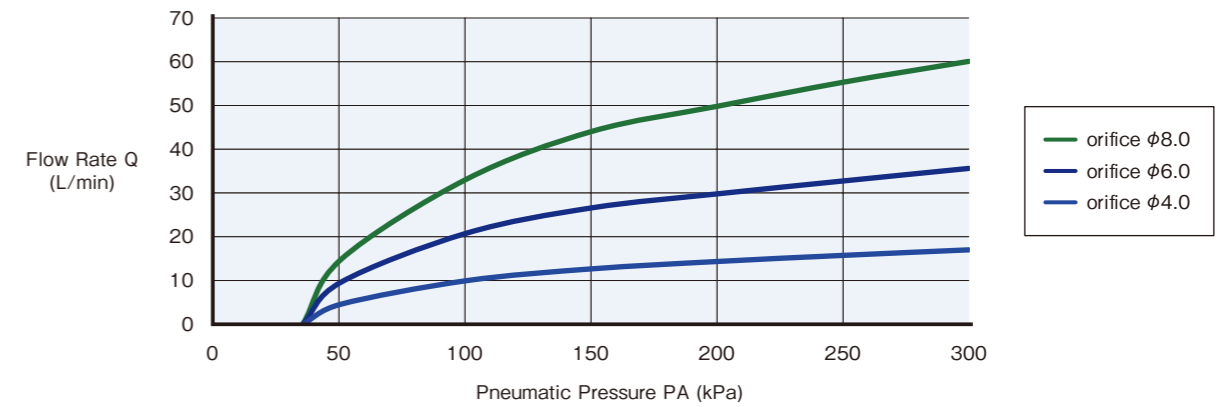
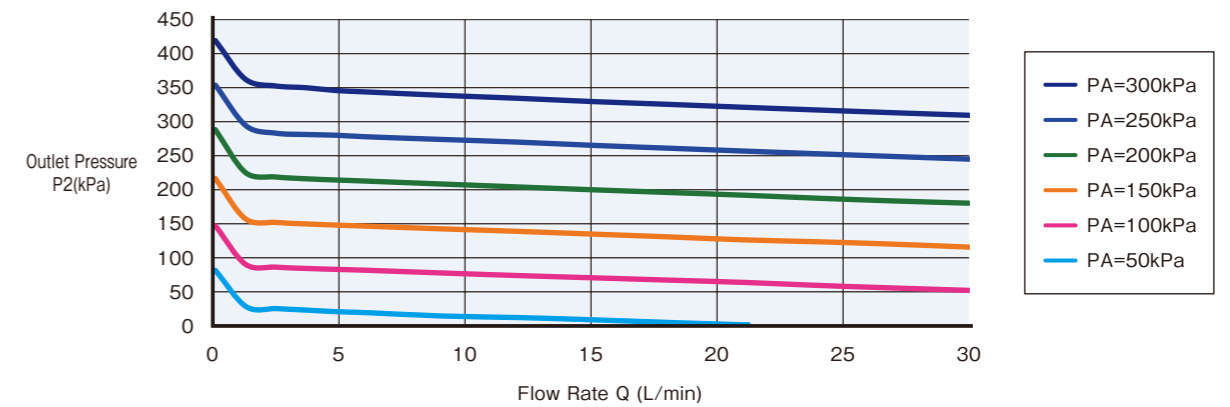

Fig.5 Outlet Pressure vs Flow Rate



HICV-110CBi8-131P(Characteristics)

Measurement Method A fixed orifice with a size of 6.0mm installed on the downstream of test unit.

Fig.1 Outlet Pressure vs Inlet Pressure

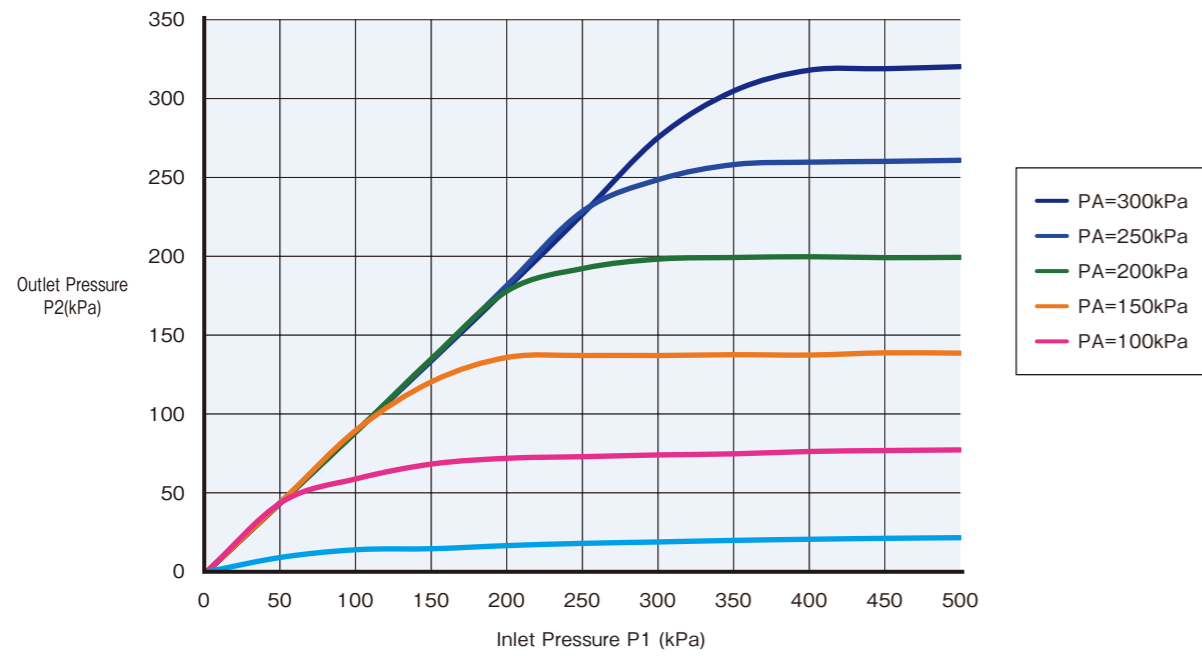
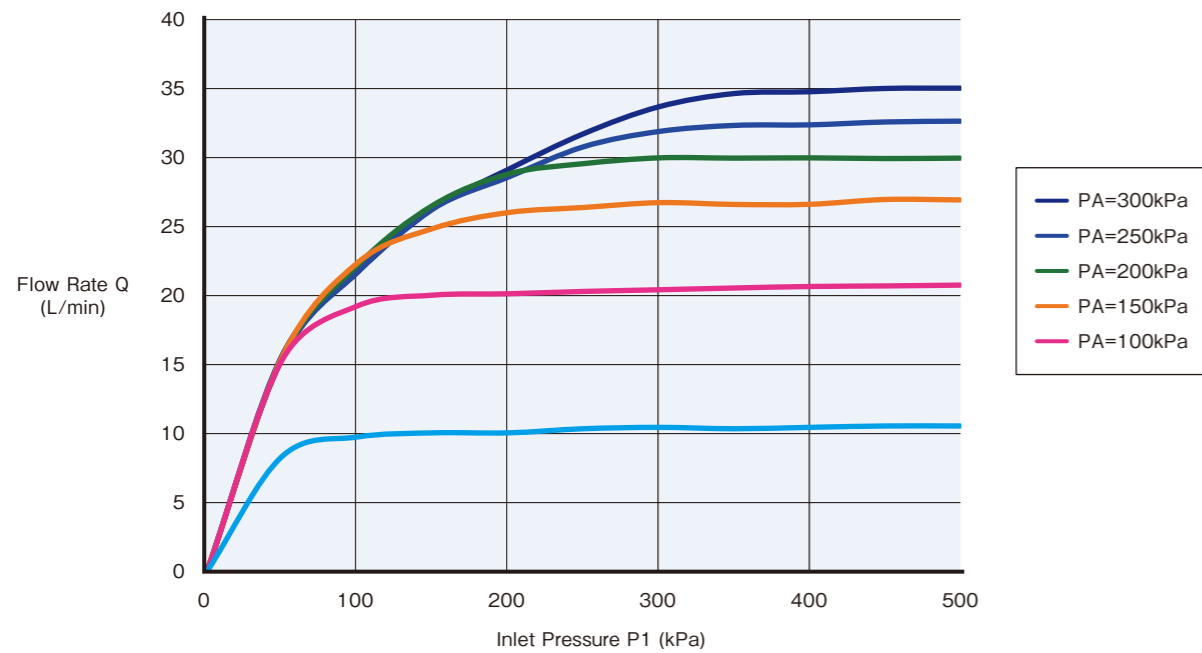

Fig.2 Flow Rate vs Inlet Pressure



Measurement Method Inlet Pressure P1=500[kPa]

Fig.3 Outlet Pressure vs Pneumatic Pressure

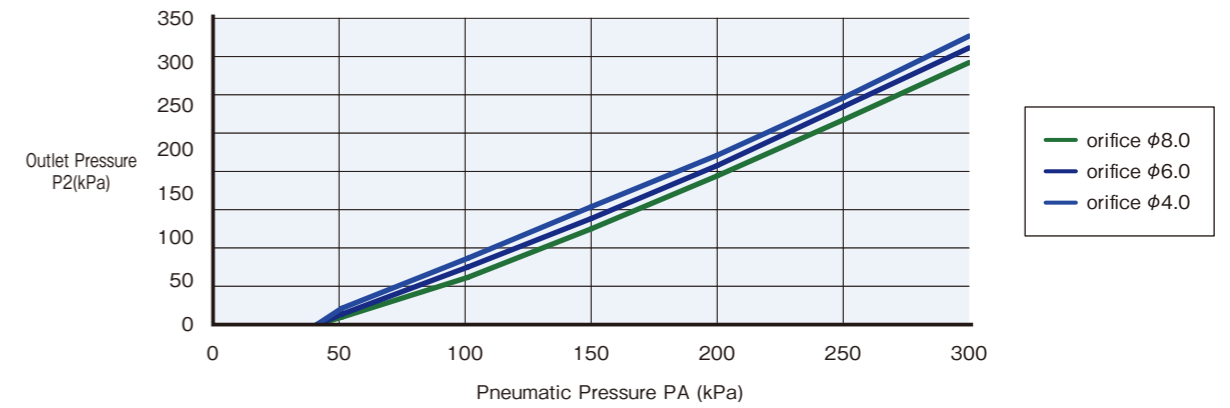

Fig.4 Flow Rate vs Pneumatic Pressure

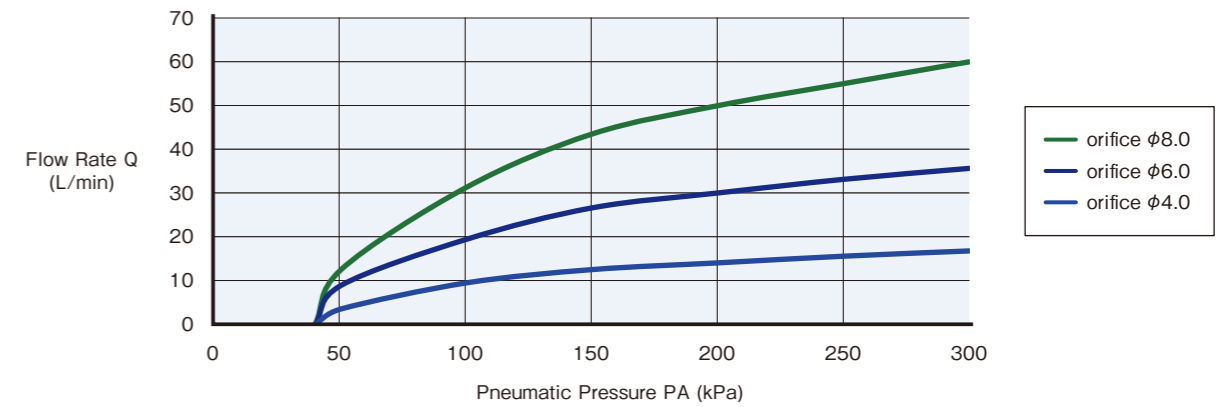
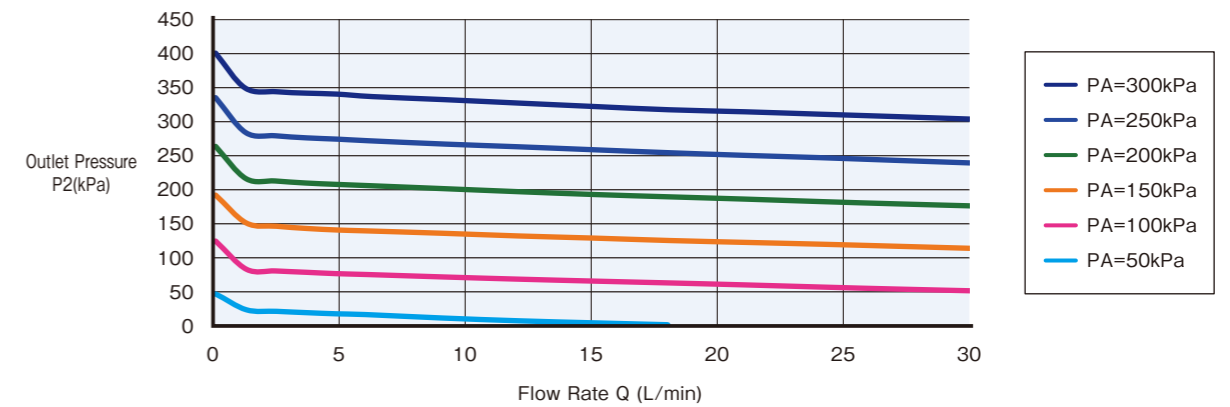

Fig.5 Outlet Pressure vs Flow Rate



Self Control Valve

HICV-130CBi*-131P



Specifications

Model Code	See Model Selection Table
Orifice Size	φ24.5 Equivalency [mm]
Connection Size	See Model Selection Table
Recommended Flow Range	10~45 [L/min] H ₂ O ※ The adjustable flow range differs according to the downstream restriction.
Applicable Media	DI Water, Corrosive Fluid
Media Pressure	IN: 0~0.5MPa OUT: 0~0.5MPa
Media Temperature	10~90°C
Ambient Temperature	0~40°C
Operational Mode	Single Pilot Type
Pneumatic Pressure	0.1~0.3MPa
Wetted Material	Diaphragm: PTFE
	Valve Body: PTFE
	Seat Stem: PTFE
	Stay: PTFE

※ Specifications are subject to change without notice.

Model Selection Table

HICV-130CBi*-131P

Connection Size
7: (I.D.XO.D.) 15.88×19.05 [mm]
8: (I.D.XO.D.) 22.23×25.4 [mm]

Dimensional Drawing

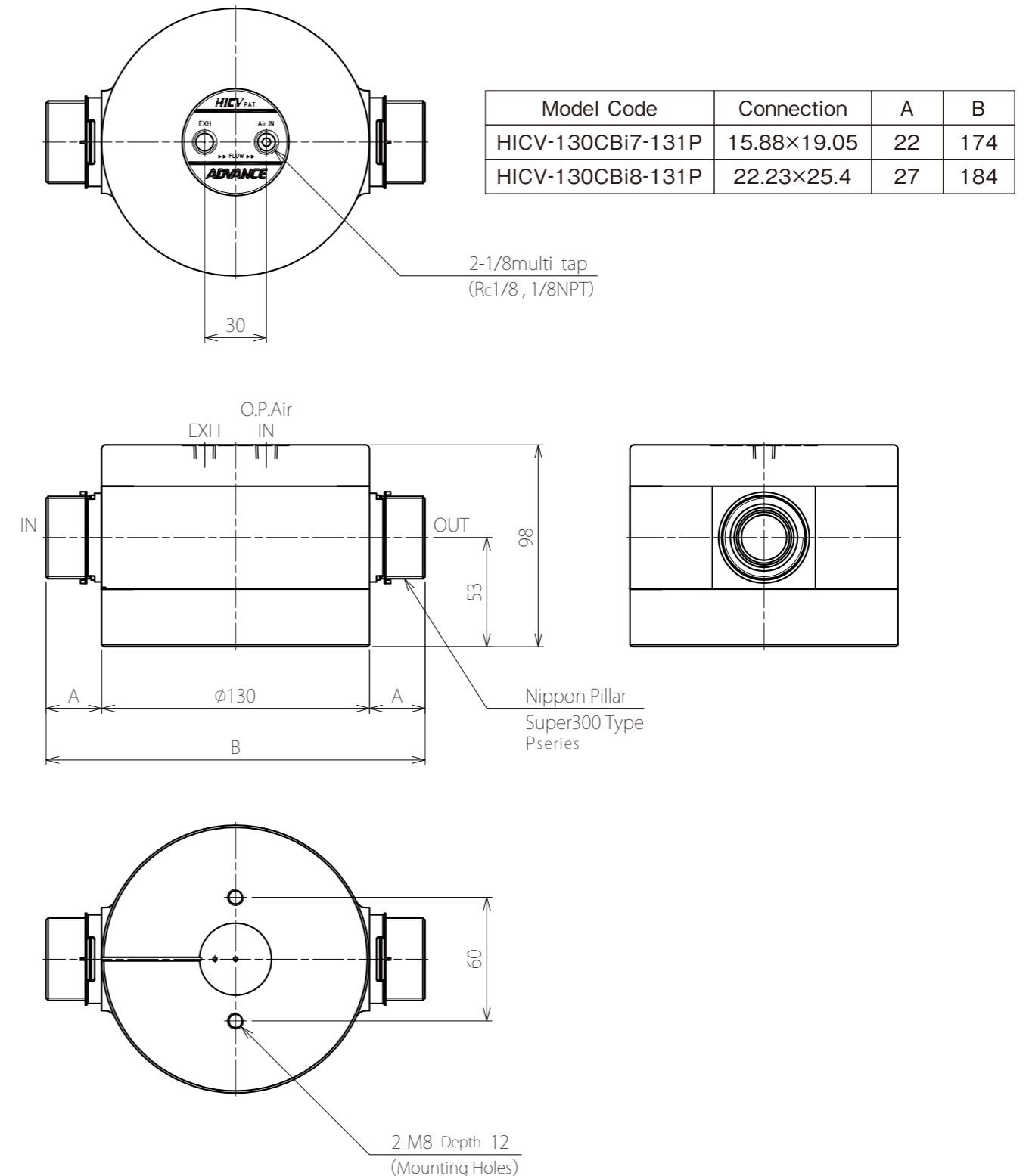

(unit : mm)

HICV-130CBi7-131P(Characteristics)

Measurement Method A fixed orifice with a size of 8.0mm installed on the downstream of test unit.

Fig.1 Outlet Pressure vs Inlet Pressure

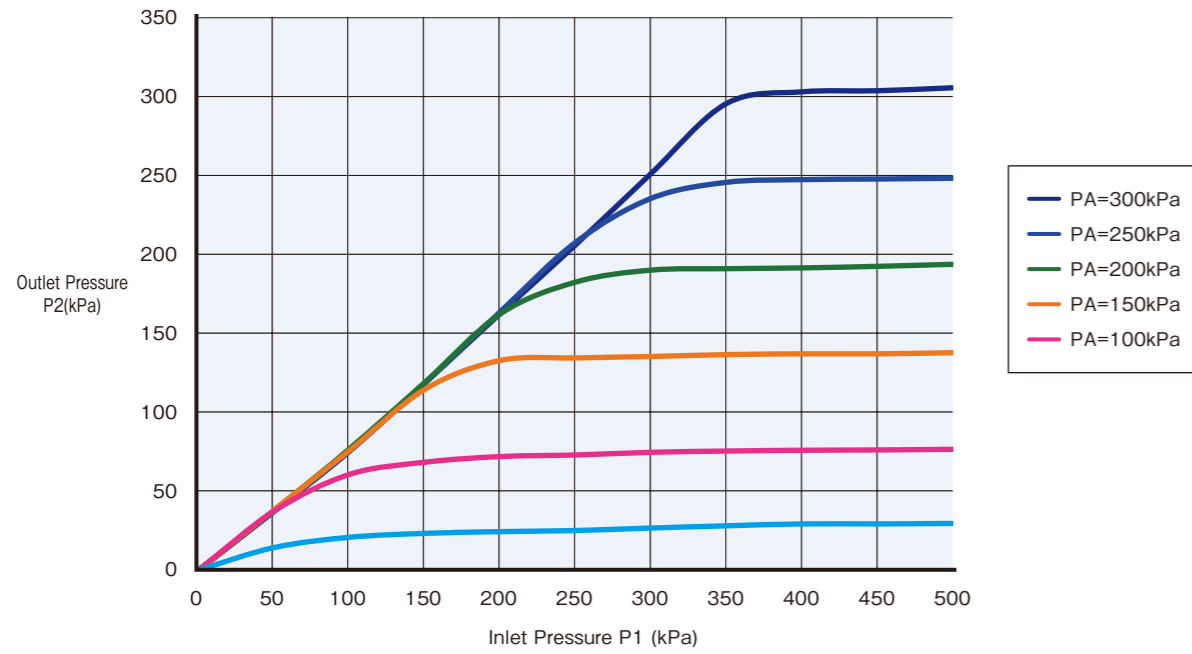
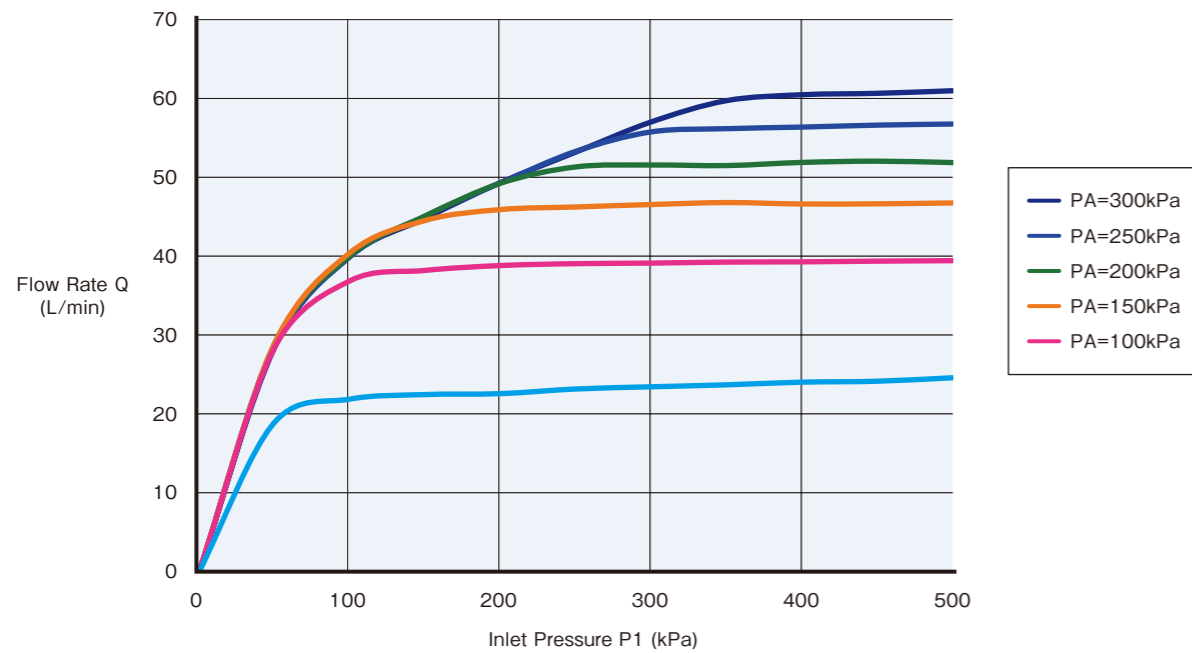

Fig.2 Flow Rate vs Inlet Pressure



Measurement Method Inlet Pressure P1=500[kPa]

Fig.3 Outlet Pressure vs Pneumatic Pressure

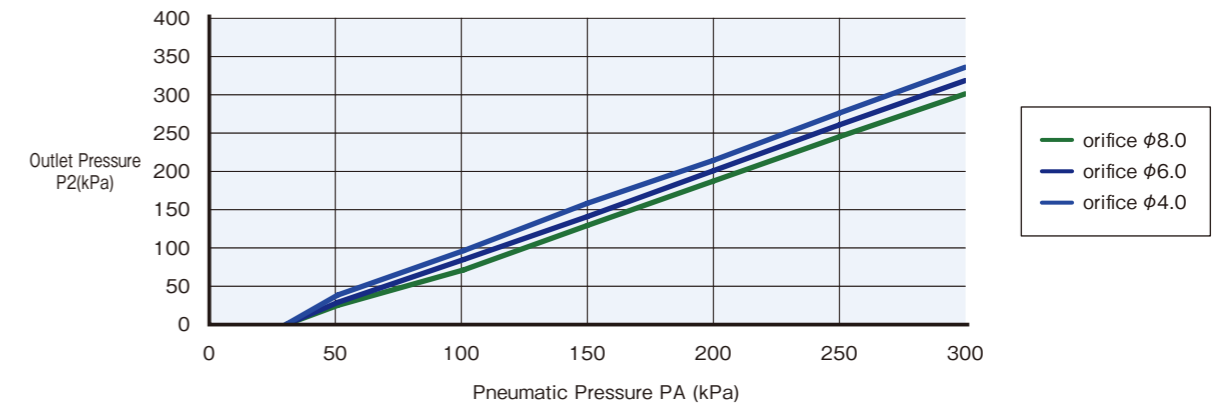

Fig.4 Flow Rate vs Pneumatic Pressure

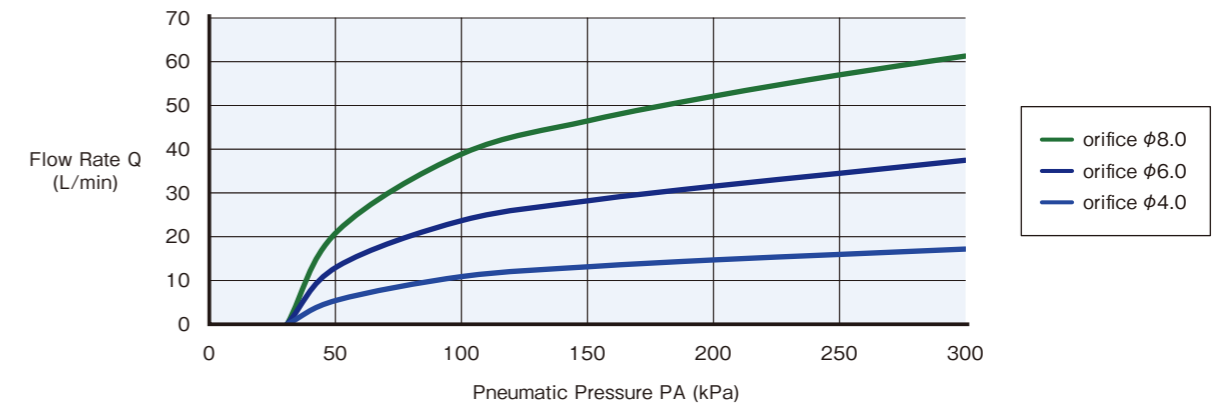
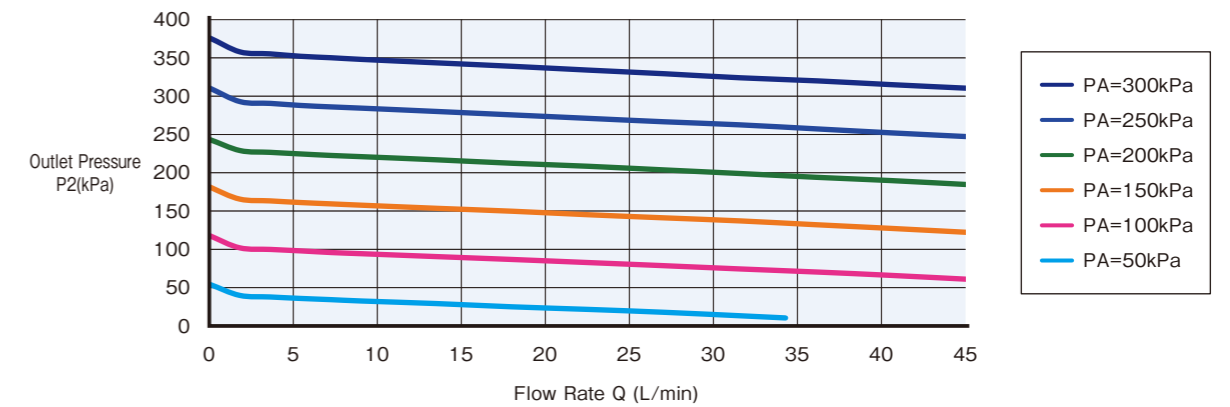

Fig.5 Outlet Pressure vs Flow Rate



HICV-130CBi8-131P(Characteristics)

Measurement Method A fixed orifice with a size of 8.0mm installed on the downstream of test unit.

Fig.1 Outlet Pressure vs Inlet Pressure

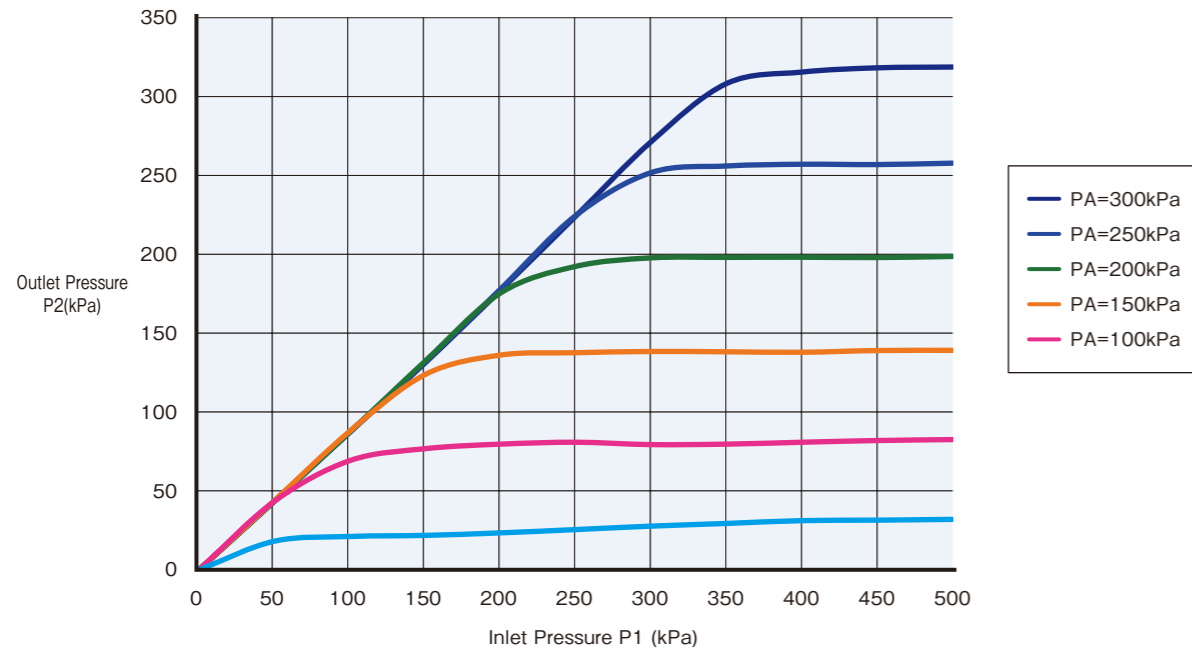
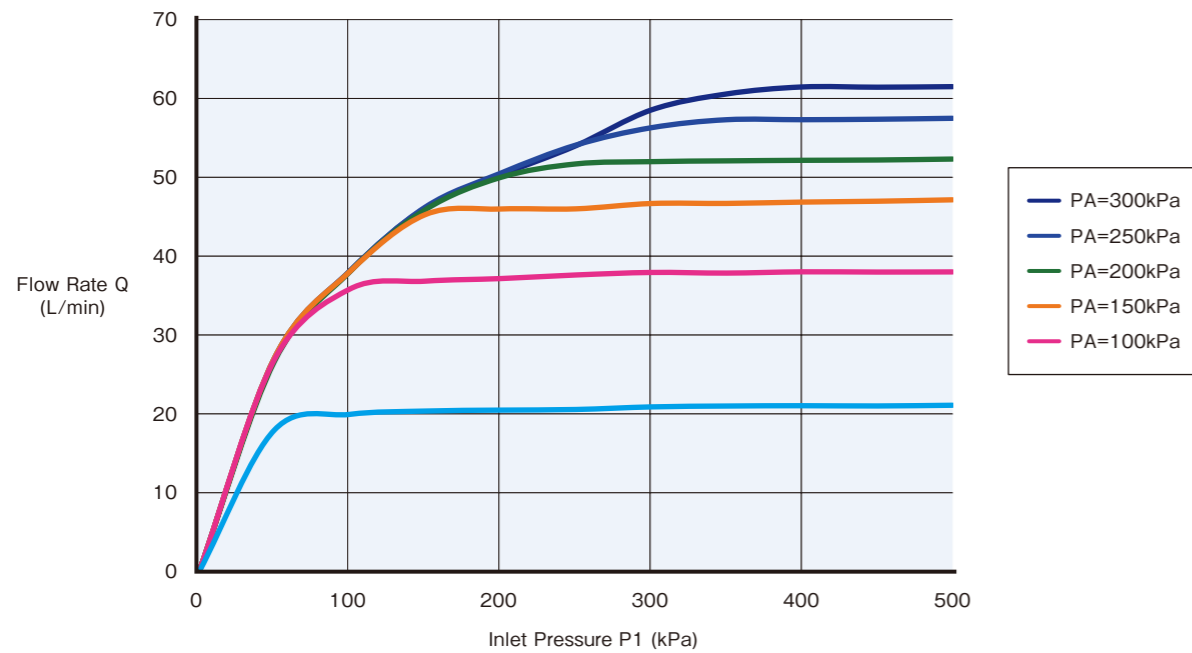

Fig.2 Flow Rate vs Inlet Pressure



Measurement Method Inlet Pressure P1=500[kPa]

Fig.3 Outlet Pressure vs Pneumatic Pressure

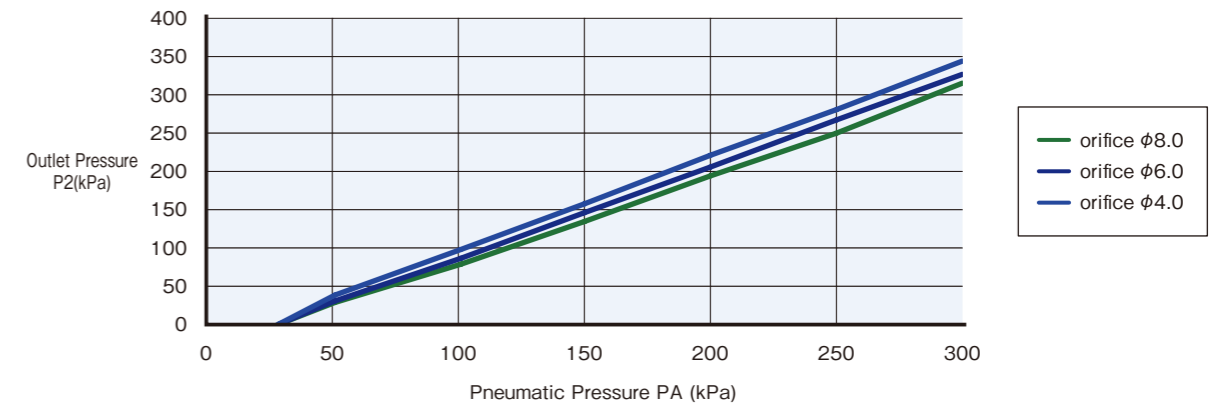

Fig.4 Flow Rate vs Pneumatic Pressure

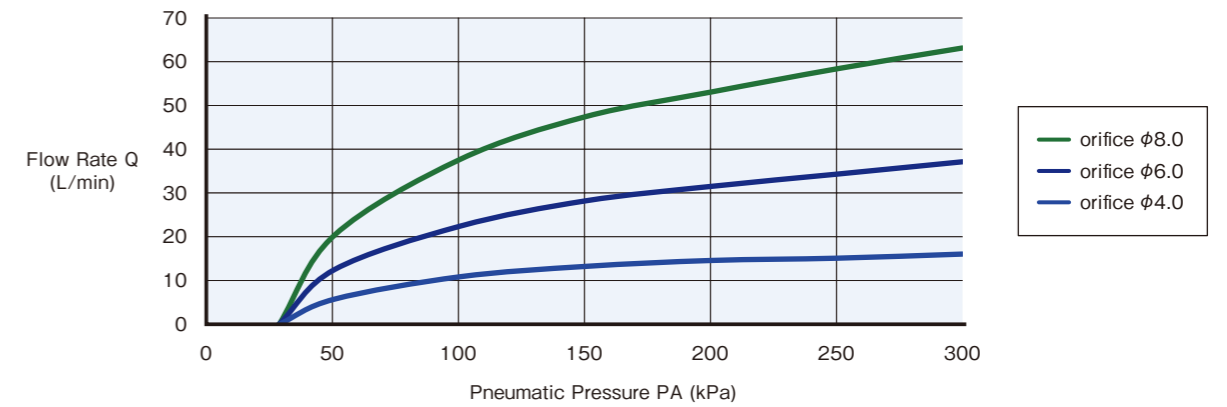

Fig.5 Outlet Pressure vs Flow Rate

